



# Equatorial Electrojet

*Babatunde Rabi  
Centre for Atmospheric Research  
National Space Research & Development Agency  
Anyigba, Nigeria*

*Email: [tunderabiu@carnasrda.com](mailto:tunderabiu@carnasrda.com);  
[tunderabiu2@gmail.com](mailto:tunderabiu2@gmail.com)*



# Outline of presentation

- Equatorial ionosphere
- Sq
- Equatorial Electrojet
- Estimation of EEJ
- Some results/observations

# Magnetic Equator

- **Magnetic (dip) equator is defined as the locus of zero dip along the surface of the earth (Cohen, 1967)**
- **Its latitude varies along the geographical longitudes**

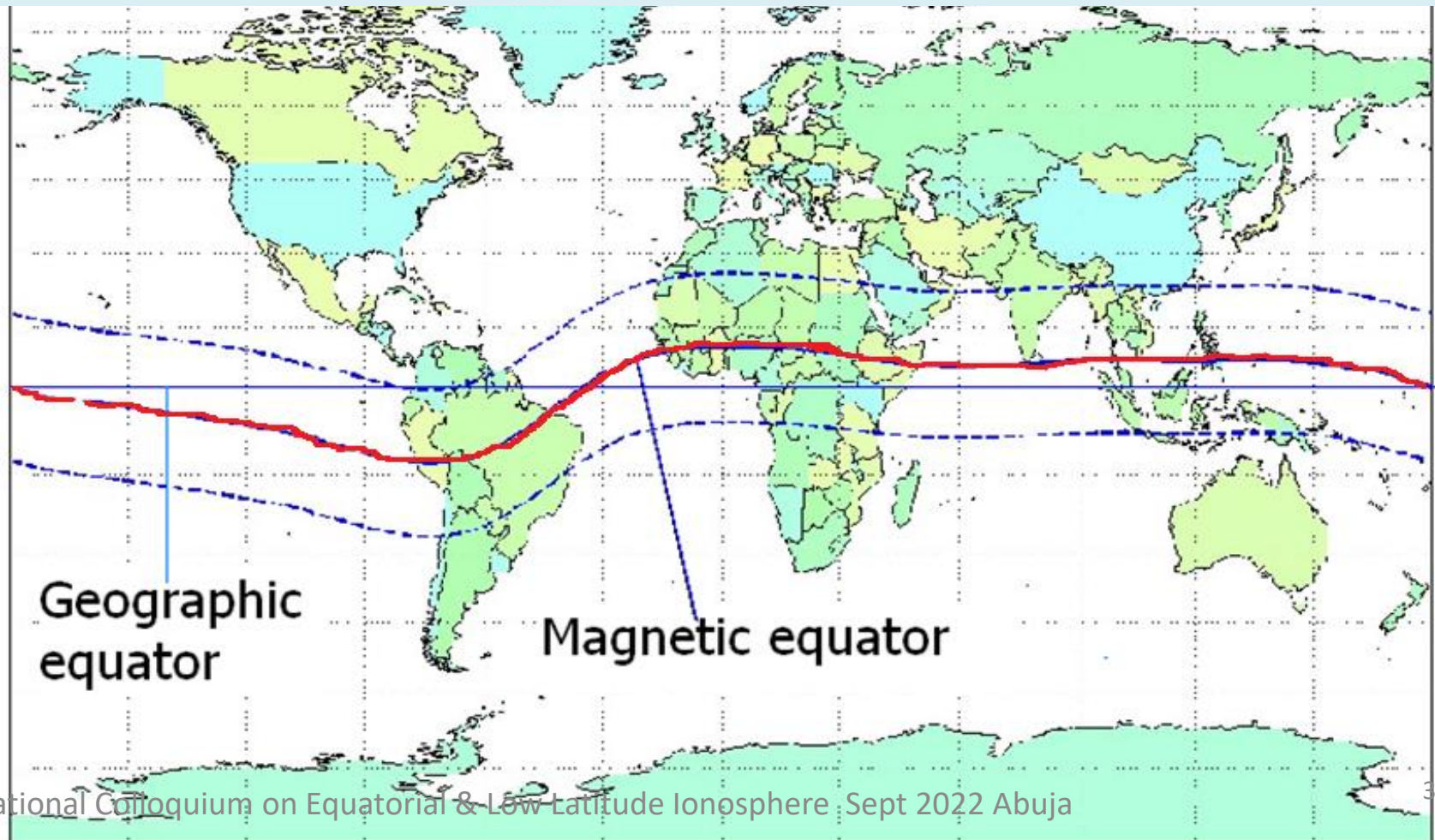



# Magnetic Equator

- In the neighbourhood of magnetic equator, there is an unusual orientation of the magnetic field with relation to the Earth
- Charged particles move more readily along magnetic field lines
- Migration of charged particles along geomagnetic field lines is associated with a two-humped latitudinal distribution of electron density, with minimum at the magnetic equator

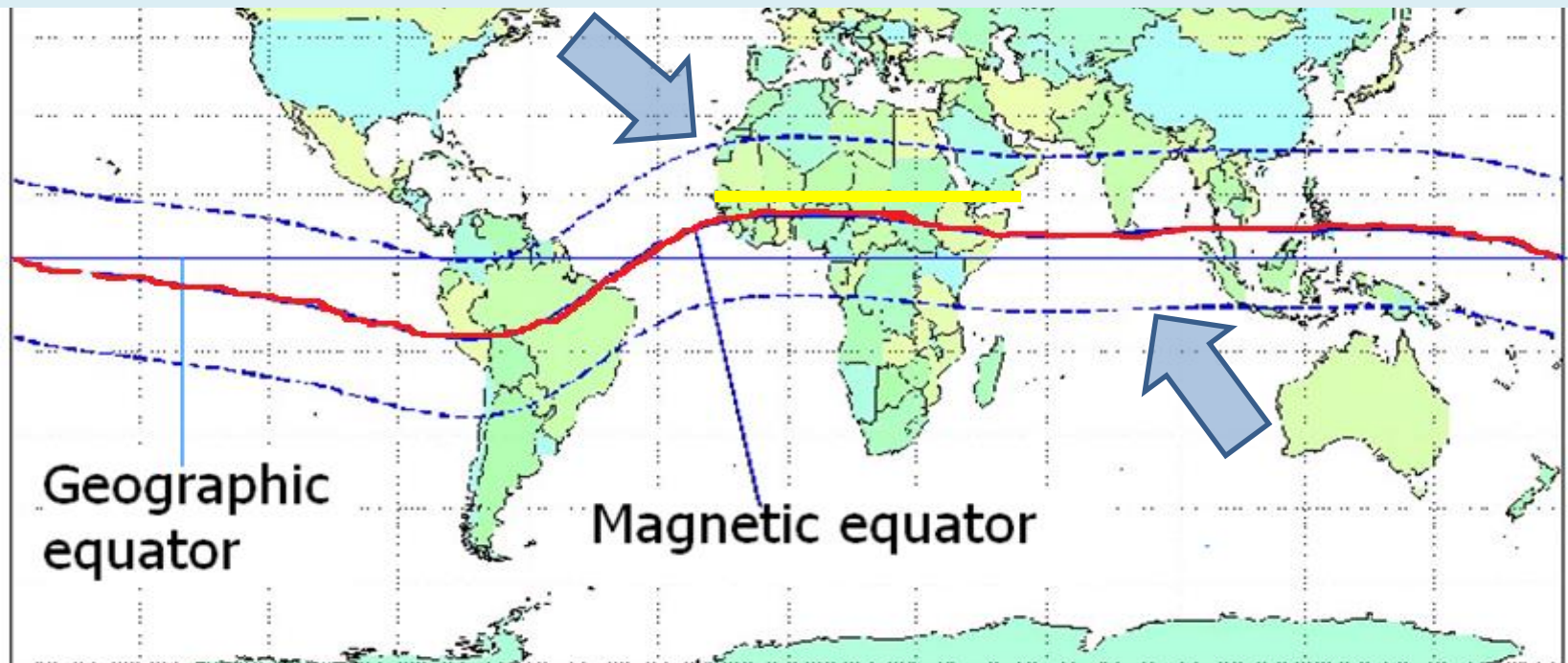

**Africa has the broadest inland range of magnetic equator over it**

3 major regions of the global ionosphere

- high-latitude  $\pm 60^\circ - 90^\circ$
- mid- latitude  $\pm 20^\circ - 60^\circ$
- equatorial  $\pm 0 - 20^\circ$

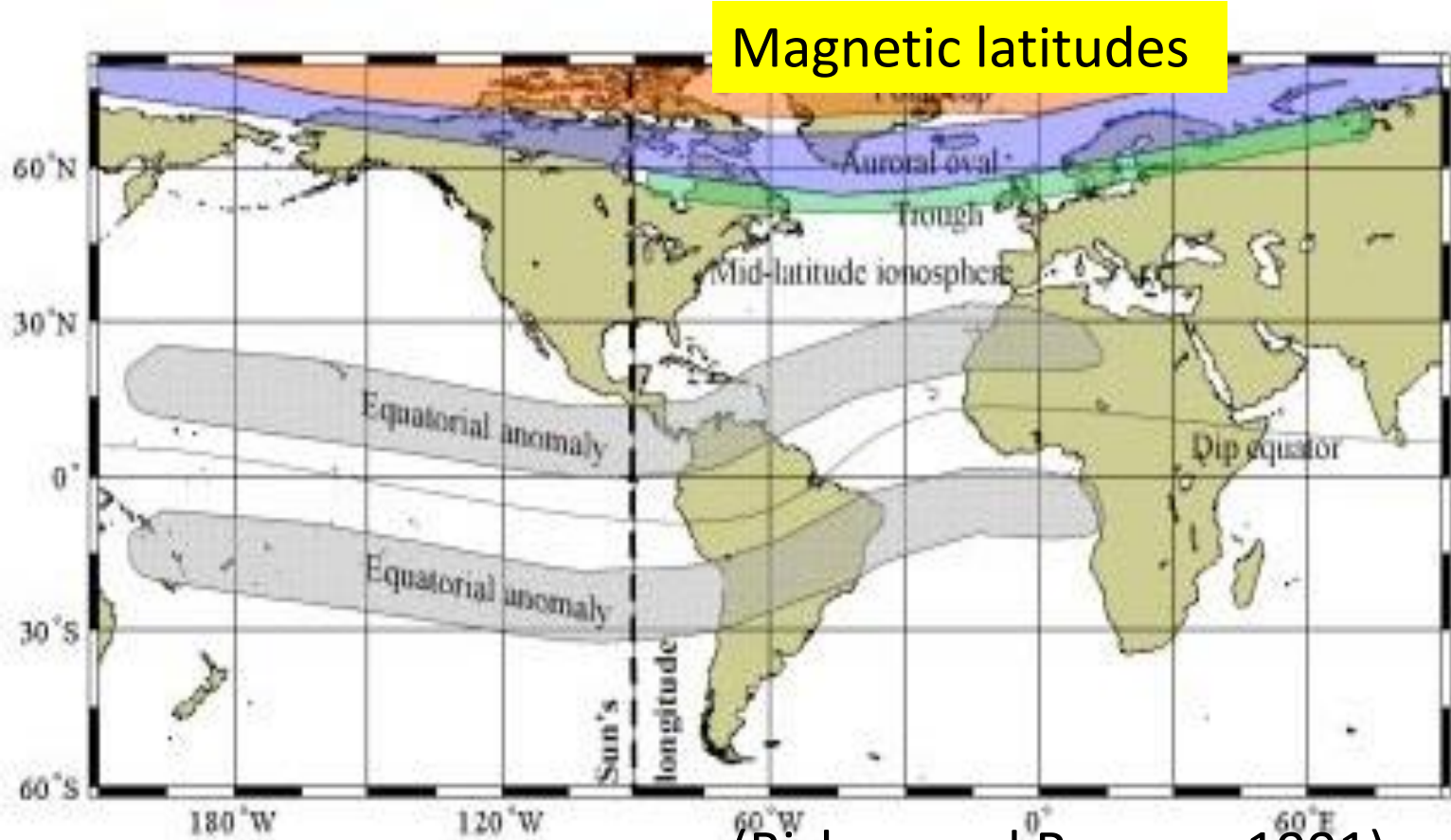

(Bishop and Rossow. 1991).



# Equatorial Region 1

- characterized with the highest values of the peak-electron density with the most pronounced amplitude and phase scintillation effects
- The combined effect of the high radiation level from the sun, & the electric and the magnetic fields of the earth results in the electrons rising and moving along the horizontal lines of the magnetic field, forces ionization up into the F layer, concentrating at  $\pm 20^\circ$  from the magnetic equator this phenomenon is called the fountain effect.
- The electrons move as far as the geomagnetic latitudes of 10 to  $20^\circ$  causing the high concentration of electrons there which are often termed equatorial anomalies (Komjathy, 1997).



# Equatorial Region 2

- The worldwide solar-driven wind results in the so-called Sq (daily solar quiet) current system in the E region of the Earth's ionosphere (100–130 km altitude)
- Resulting from this current is an electrostatic field directed E-W (dawn-dusk) in the equatorial day side of the ionosphere
- At the magnetic dip equator, where the geomagnetic field is horizontal, this electric field results in an enhanced eastward current flow within  $\pm 3^\circ$  of the magnetic equator, known as the equatorial electrojet

# Geomagnetic elements

$$H = F \cos I$$

$$F = H \sec I$$

$$Z = H \tan I = F \sin I$$

$$X = H \cos D$$

$$Y = H \sin D$$

$$H^2 = X^2 + Y^2$$

$$F^2 = X^2 + Y^2 + Z^2$$

$$\tan I = Z/H$$

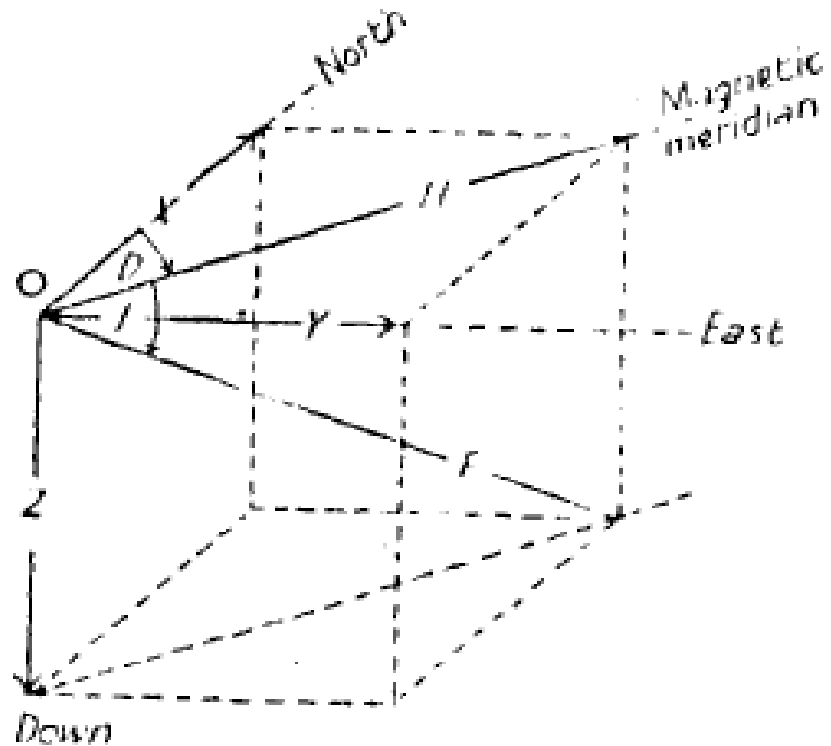

- Field either specify by (X,Y,Z) or (H, D, Z)





# Temporal Variation of Geomagnetic Field

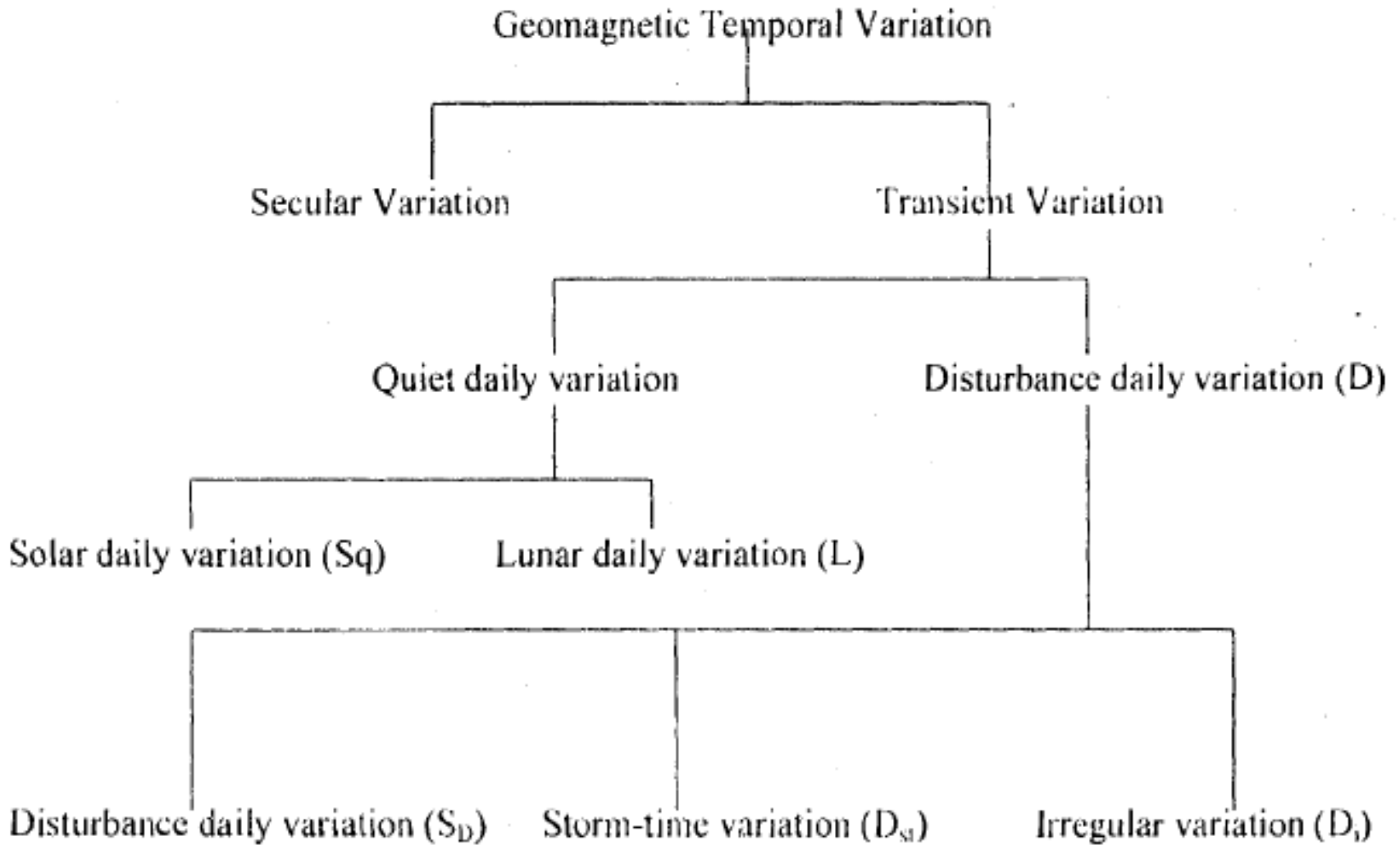

# Sq & EEJ

- solar quiet daily Sq currents is a worldwide ionospheric currents responsible for Sq variation in the Earth's magnetic field.
- Sq center is located at about 118 km and has a focus in each of the hemispheres (Onwumechili, 1997).
- In a narrow region around the dip equator, the H component of Sq field becomes very large and positive

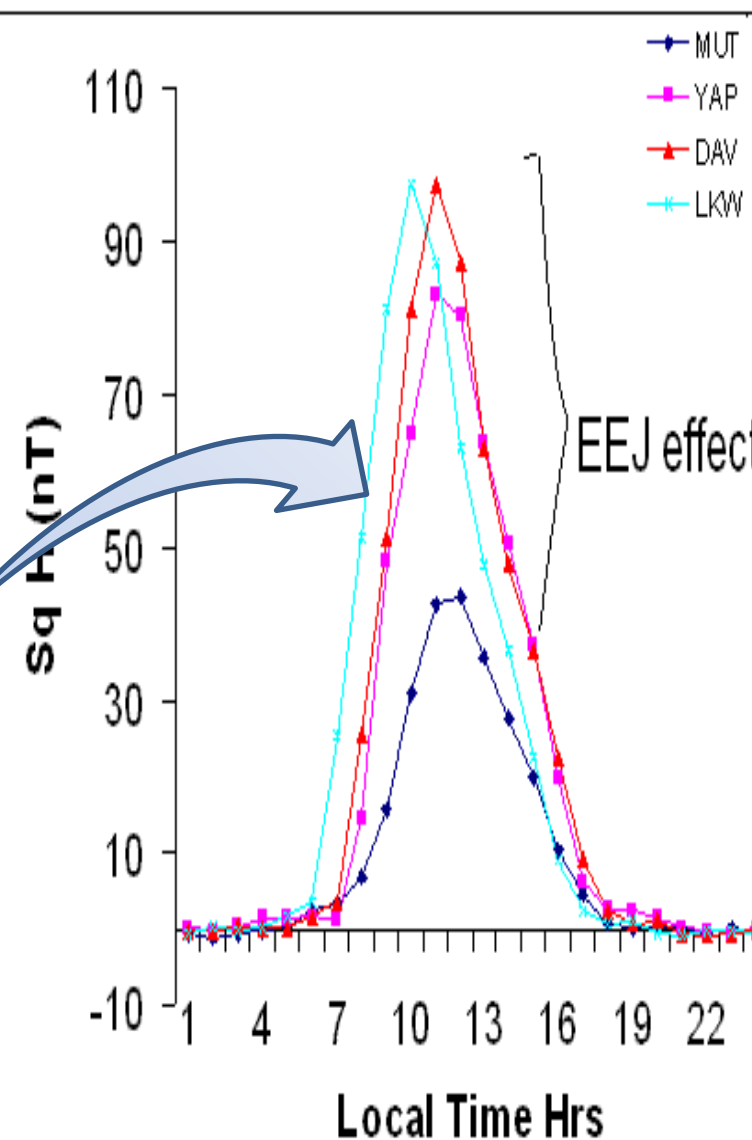

The enhancement of Sq at YAP, DAV and LAW on 8<sup>th</sup> April 2008 due to electrojet effect (After Rabiou et al, 2009a)



# Sq & EEJ

- This sudden enhancement, first observed at Huancayo in 1922, has been attributed to a narrow intense ionospheric current which flow eastwards within the narrow strip  $\pm 3^\circ$  flanking the dip equator (Egedal, 1947, and others)
- This unique equatorial ionospheric current was later, in May 1951, named by Sydney Chapman 'the Equatorial electrojet' in his presidential address to the Physical Society of London.

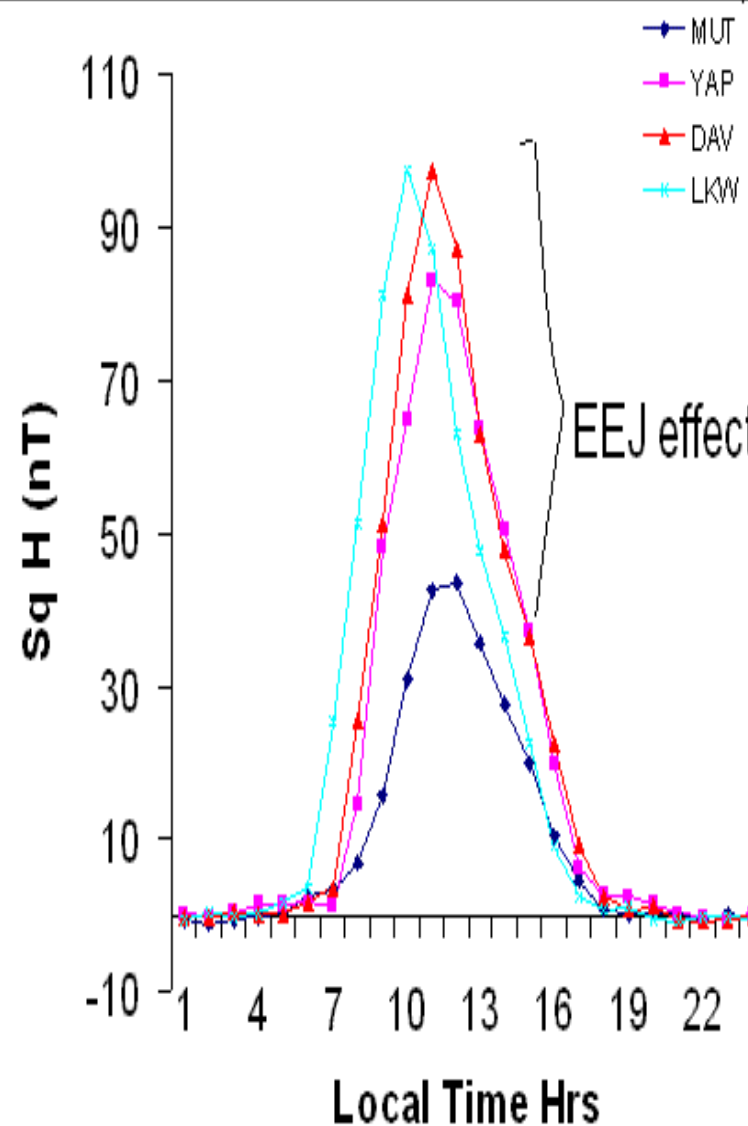

The enhancement of Sq at YAP, DAV and LKW on 8<sup>th</sup> April 2008 due to electrojet effect (After Rabiou et al, 2009a)



# Equatorial Electrojet

- The E (dynamo) region of the equatorial ionosphere consists of 2 layers of currents responsible for the quiet solar daily variations in Earth's magnetic field:
- Worldwide solar quiet daily variation, WSq (altitude  $118 \pm 7$  km), responsible for the global quiet daily variation observed in the earth's magnetic field.
- Equatorial electrojet, EEJ - an intense current flowing eastward in the low latitude ionosphere within the narrow region,  $\pm 3^\circ$ , flanking the dip equator (altitude  $106 \pm 2$  km) (Chapman, 1951, Onwumechili, 1992)
- Enhanced (Cowling) conductivity associated with the special equatorial magnetic field configuration results in the strong daytime EEJ currents



# Equatorial Electrojet

- The equatorial electrojet (EEJ) flows as an enhanced eastward current in the daytime E region ionosphere between 100 and 120 km height at the Earth's magnetic equator.
- The flowing currents in the ionosphere induce magnetic perturbations on the ground.



# Equatorial Electrojet

- The ionospheric current system is a result of a dynamo action of the horizontal wind system and the electrical conductivity of the ionosphere in the presence of the electrons and ions.
- The EEJ causes the large daily variations of the Horizontal component of magnetic field intensity recorded by ground magnetometers near the magnetic equator
- the concentration of ionospheric current near the magnetic equator is a result of the high value of electrical conductivity of the upper atmosphere at the dip equator, which arises from an inhibition of hall current due to the horizontal configuration of the Earth`s magnetic field and the horizontal stratification of the ionosphere

*Heelis, 2004; Forbes, 1981*

# Equivalent currents

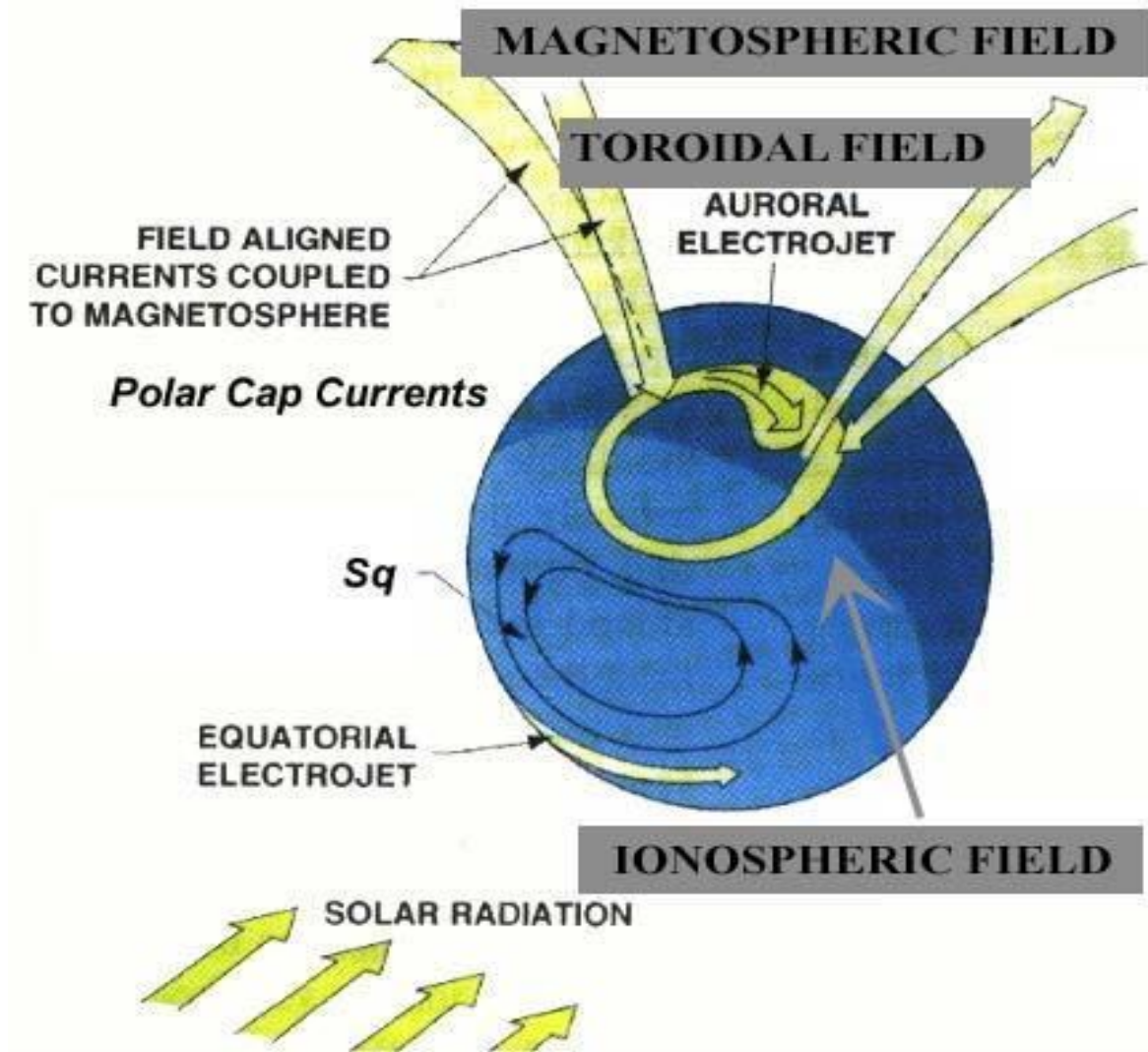

Source: NASA/GSFC & the Danish Space Research Institute (DSRI).

# Counter electrojet CEJ

- On occasion, at quiet periods during certain hours of the day, particularly in the morning and evening hours,
- the EEJ reverses direction and flows westwards giving rise to the so-called 'counter electrojet (CEJ)' phenomenon

(Gouin, 1962; Gouin & Mayaud, 1967).

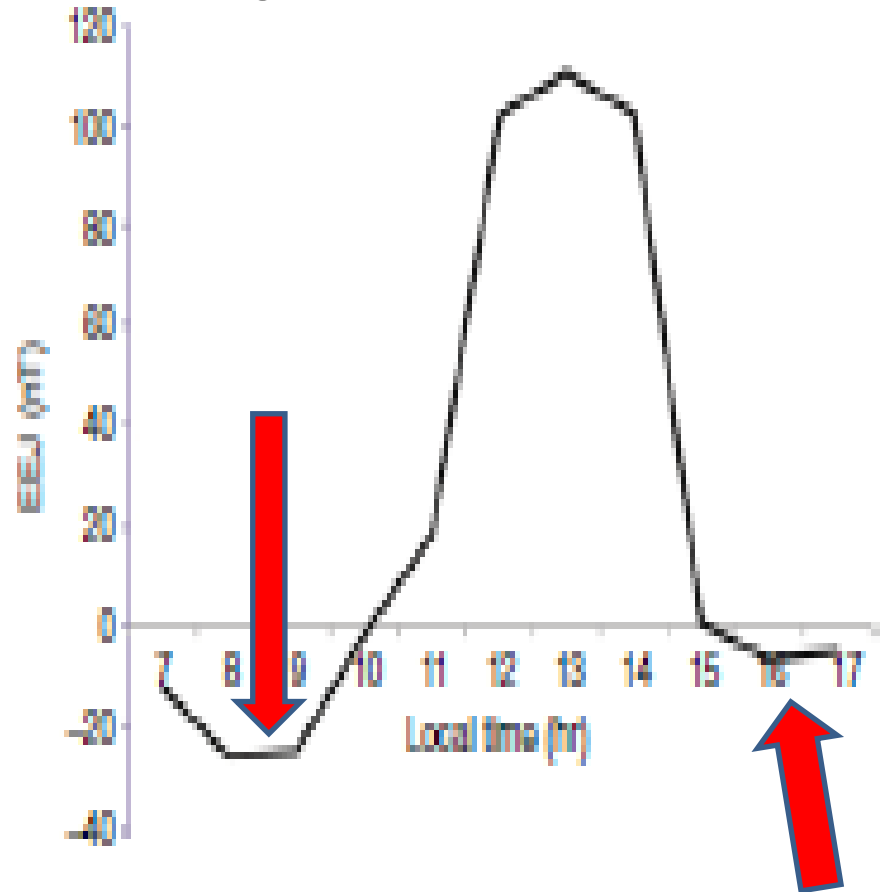

A typical diurnal variation of the equatorial electrojet (EEJ) on 2 March 2009 at Addis Ababa showing CEJ – morning and afternoon

Rabiu, et al., 2017





# Manifestations of EEJ

- Spatial structures of its intense current density
- configurations & regular temporal variations of its current system
- magnetic fields of its current system
- the ionospheric plasma density irregularities generated by the turbulent flow of the EEJ current
- the electric fields and ionospheric plasma drifts in the dip equatorial zone
- the quiet counter equatorial electrojet CEJ
- temporal variabilities of the above phenomenon.



# Geomagnetic field variations

- Spatial (over space)
  - Latitudinal
  - Longitudinal
  
- Temporal (over time)
  - Secular
  - Transient

# Spatial Variations

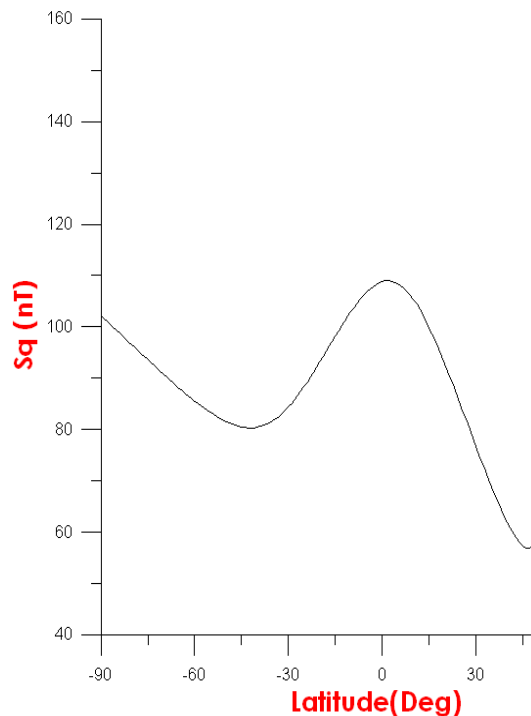

Owolabi, 2012

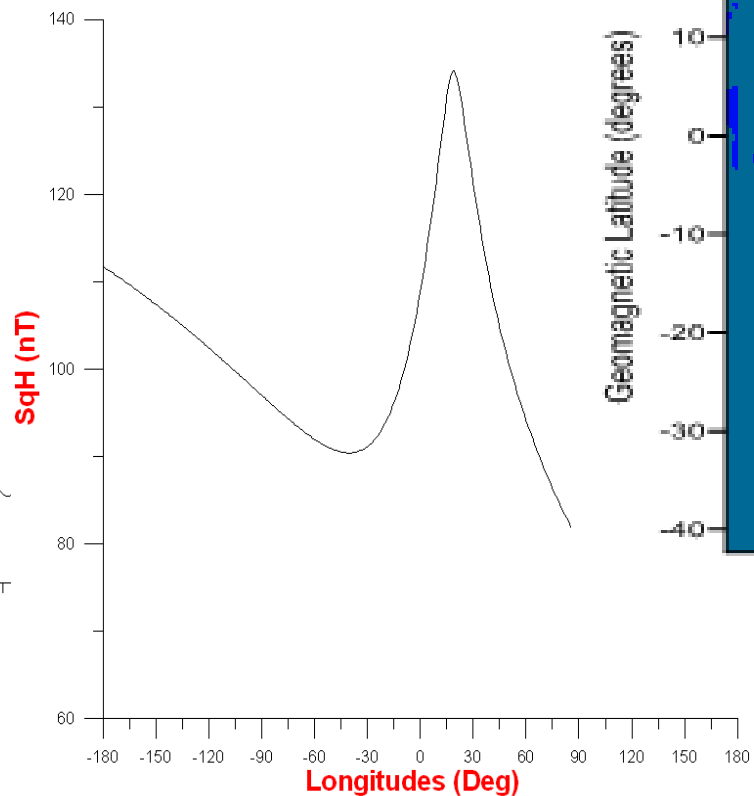

Owolabi, 2012

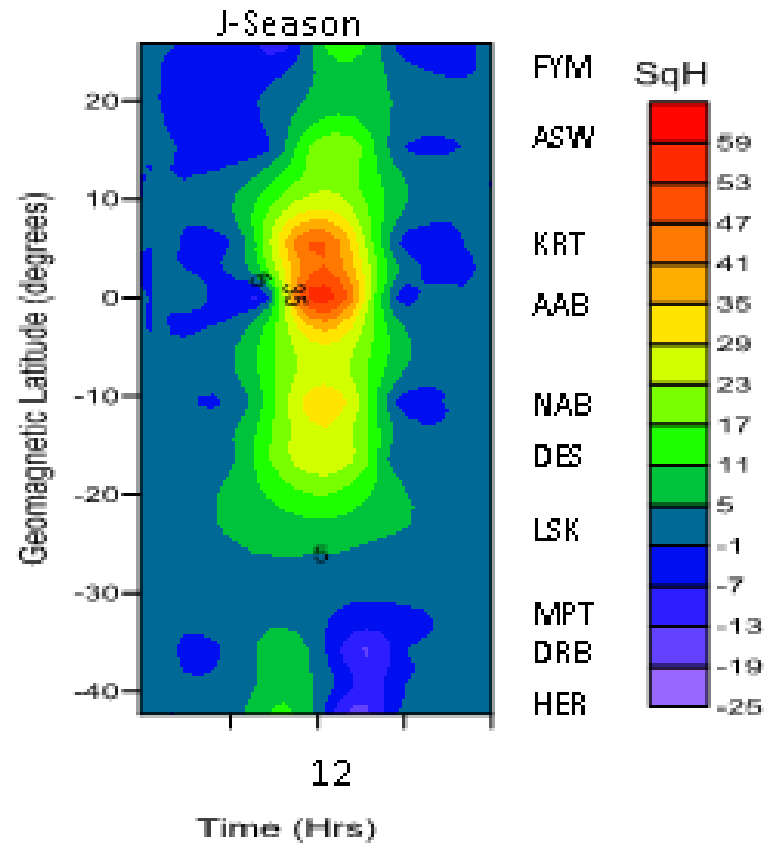

Bello 2011

# Spatial and Seasonal variation of Sq(H) along the African low latitudes

- Sq (H) is greater in all seasons in the neighbourhood of dip equator
- Obviously due to EEJ effect
- Max effect at Autumn (Sept) Equinox

Bolaji et al 2015 ..

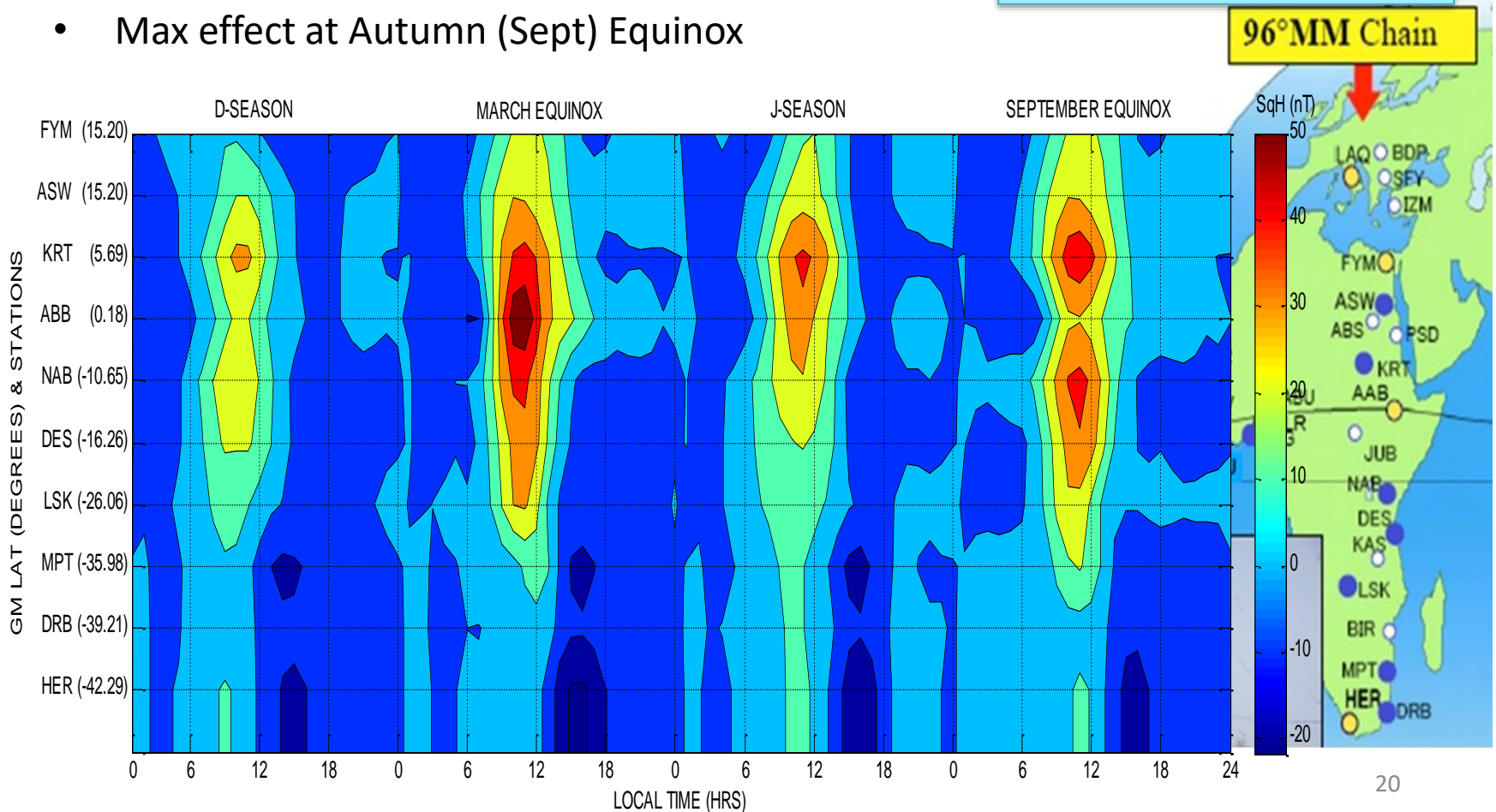

- The diurnal variations of H, D and Z components vary with geomagnetic coordinates

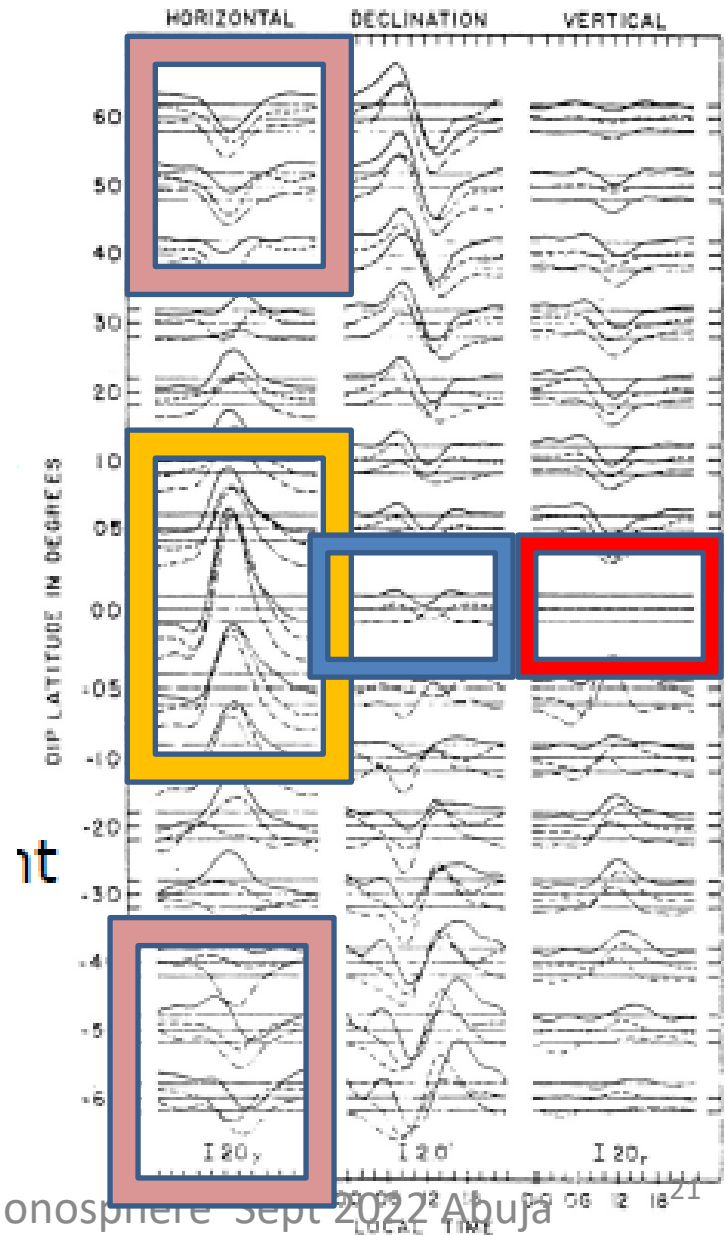

## Spatial variation of EEJ

Electrojet in ionosphere

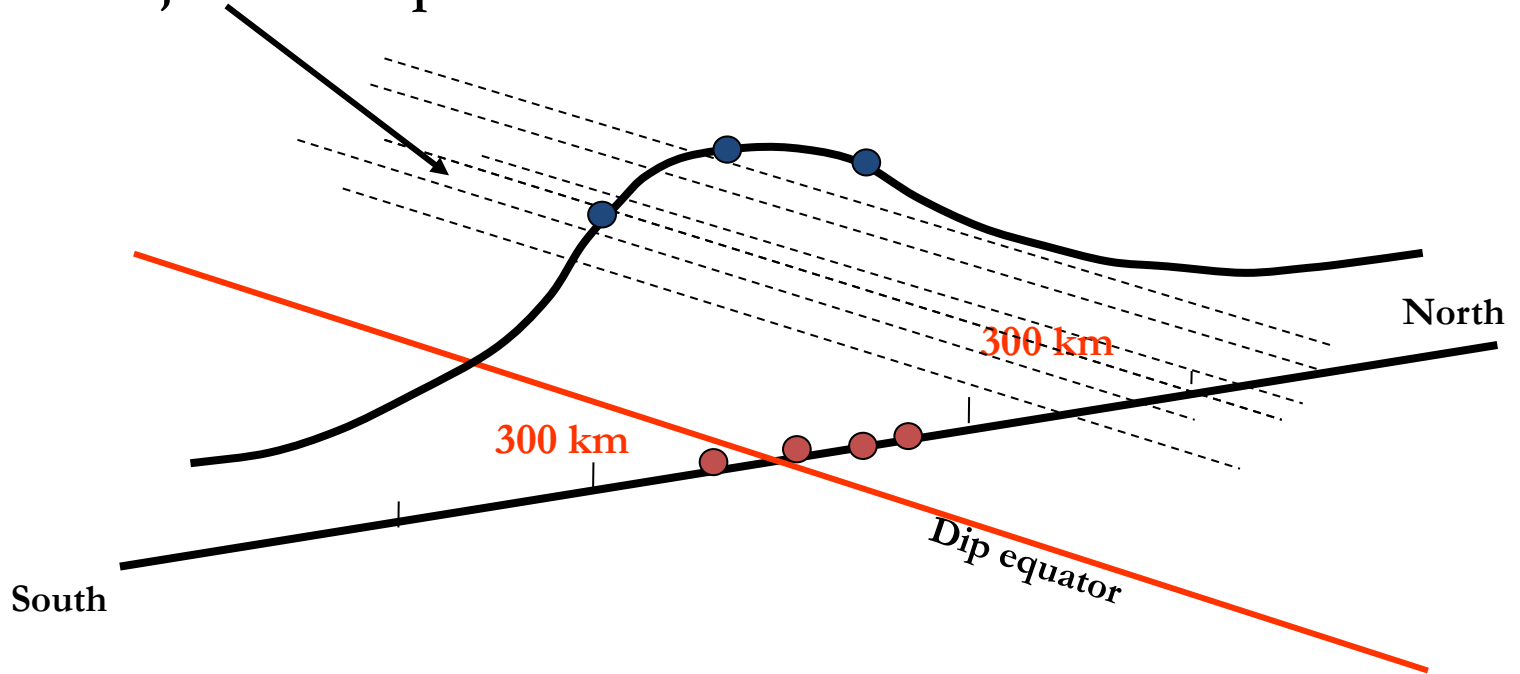

**Geometry of measurement of EEJ as observed on ground**

## Spatial variation of EEJ contd

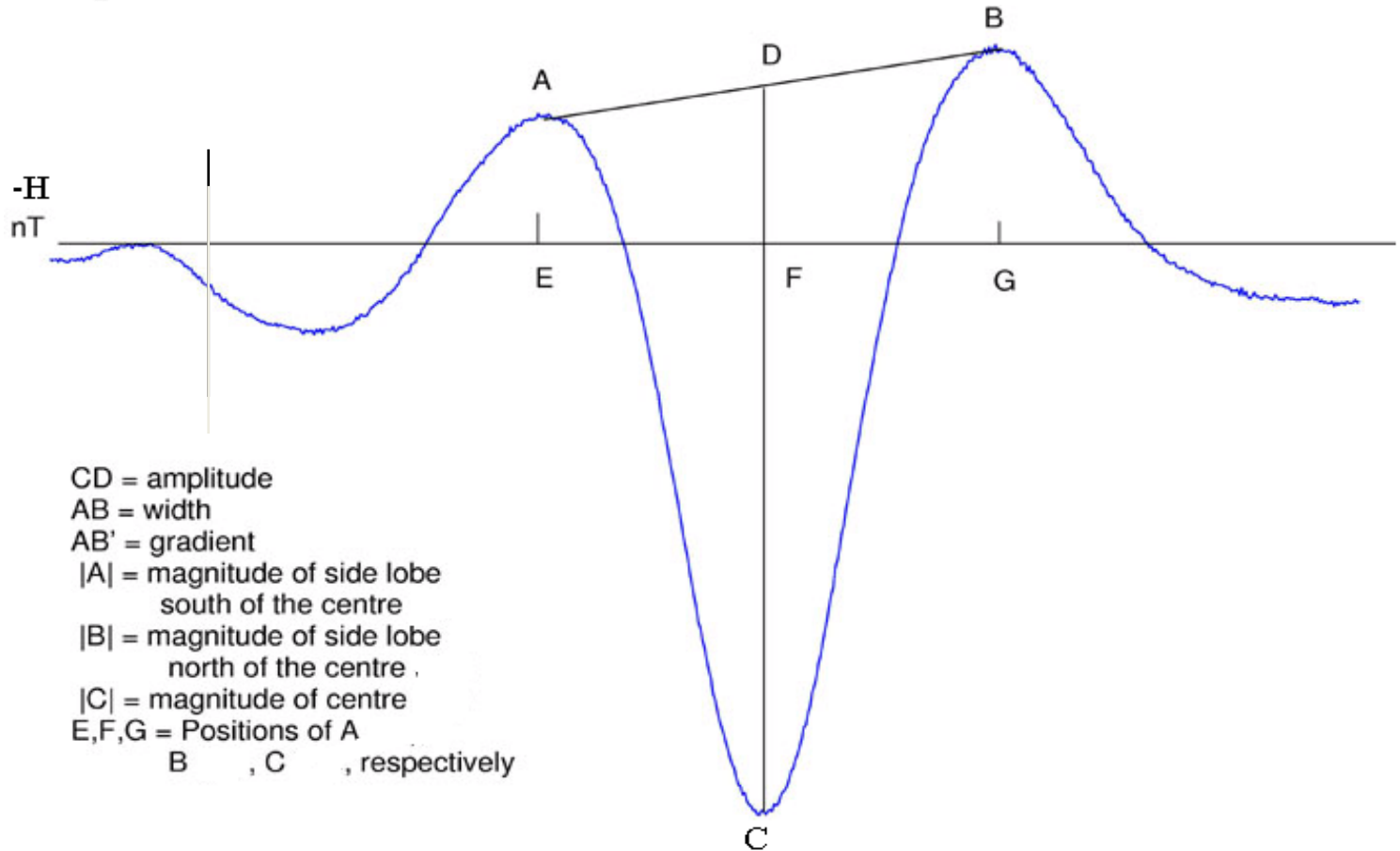

**Satellite view of EEJ has two side lobes with maximum turning points and a minimum turning point between**

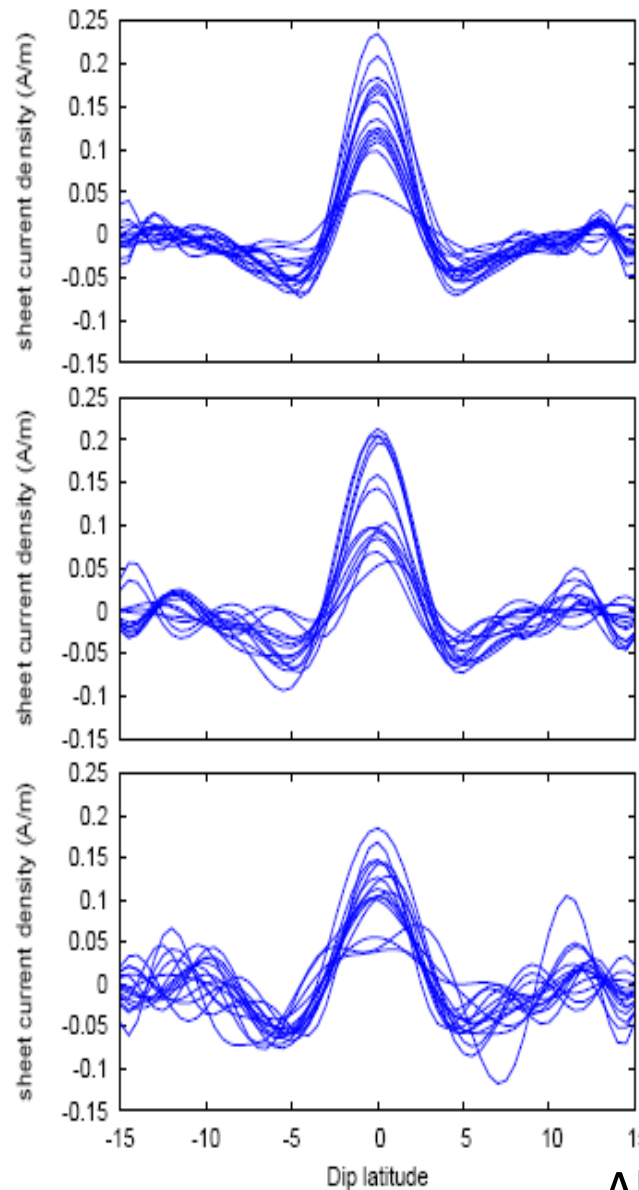
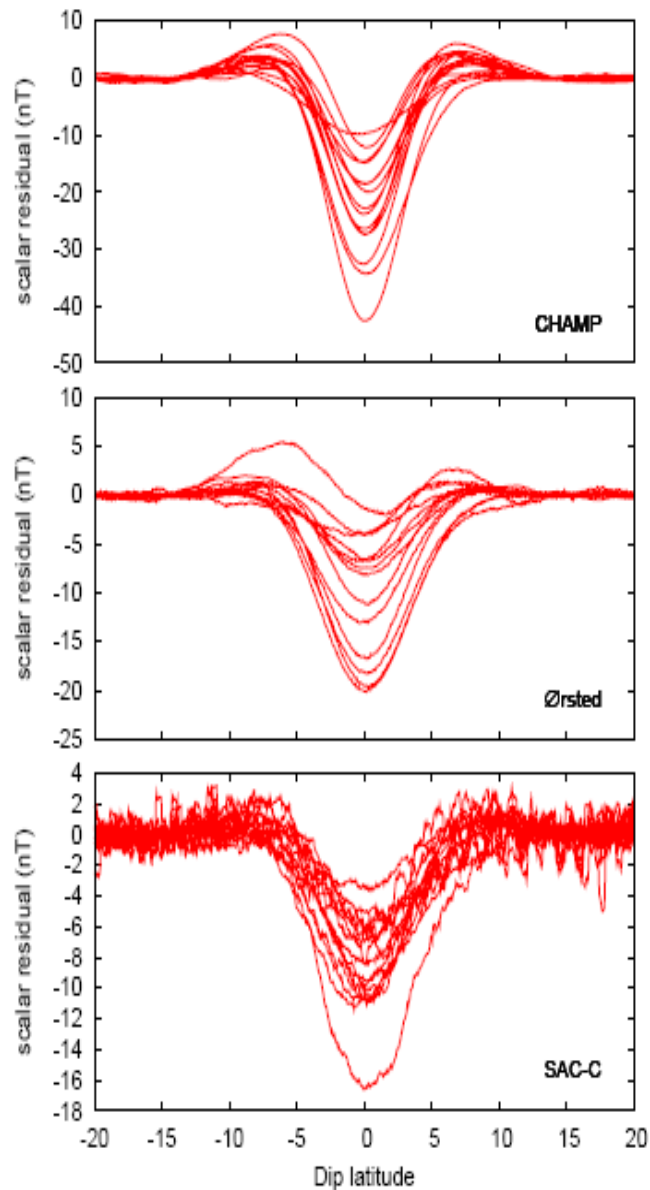

Left: magnetic field residuals. The CHAMP residuals are of higher quality and also stronger due to CHAMP's lower altitude.

Right: EEJ signal after inverting magnetic data..

Alken & Mauss, 2007



IGRF model of The Earth's magnetic field at 400 km altitude due to the ionospheric current systems.

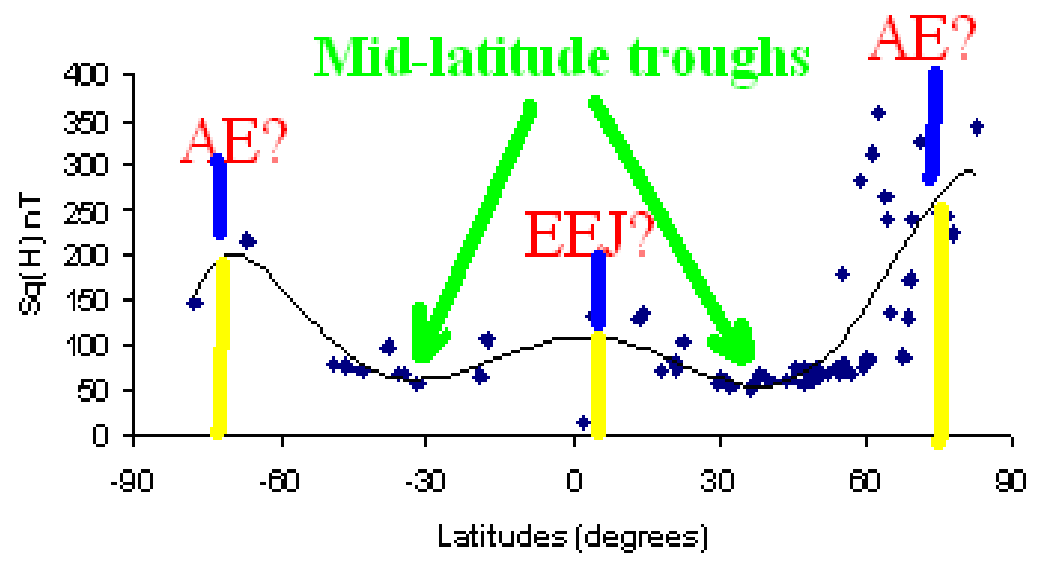
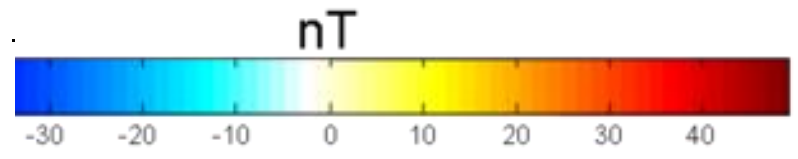
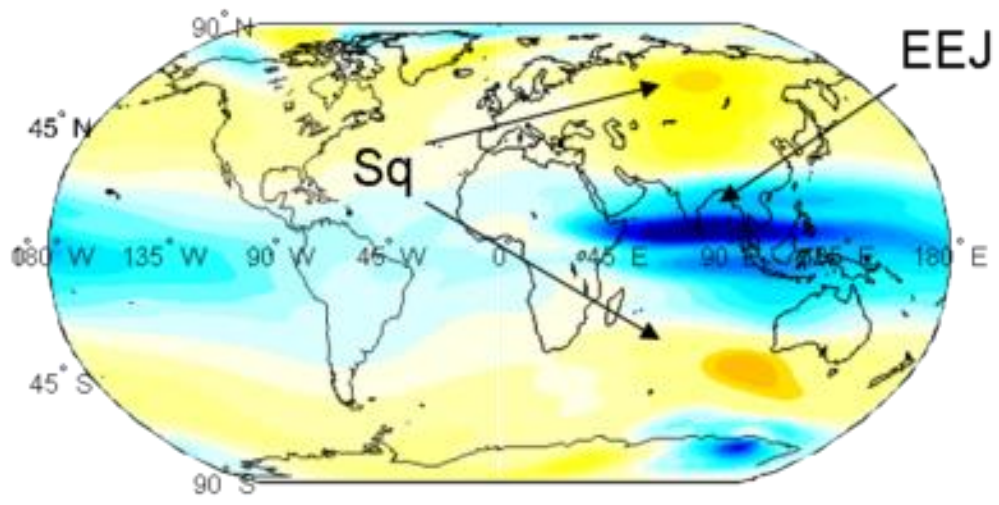

Latitudinal variation of Annual Sq 1996

The equatorial intensification of the magnetic field is due to EEJ.

(Rabiu et al, 2006)



# The field of the EEJ from CHAMP data

Variation with local time of the along-track second derivative of the equatorial electrojet field (in  $nT/s^2$ ), longitudinal component

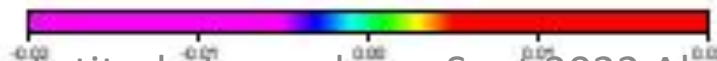
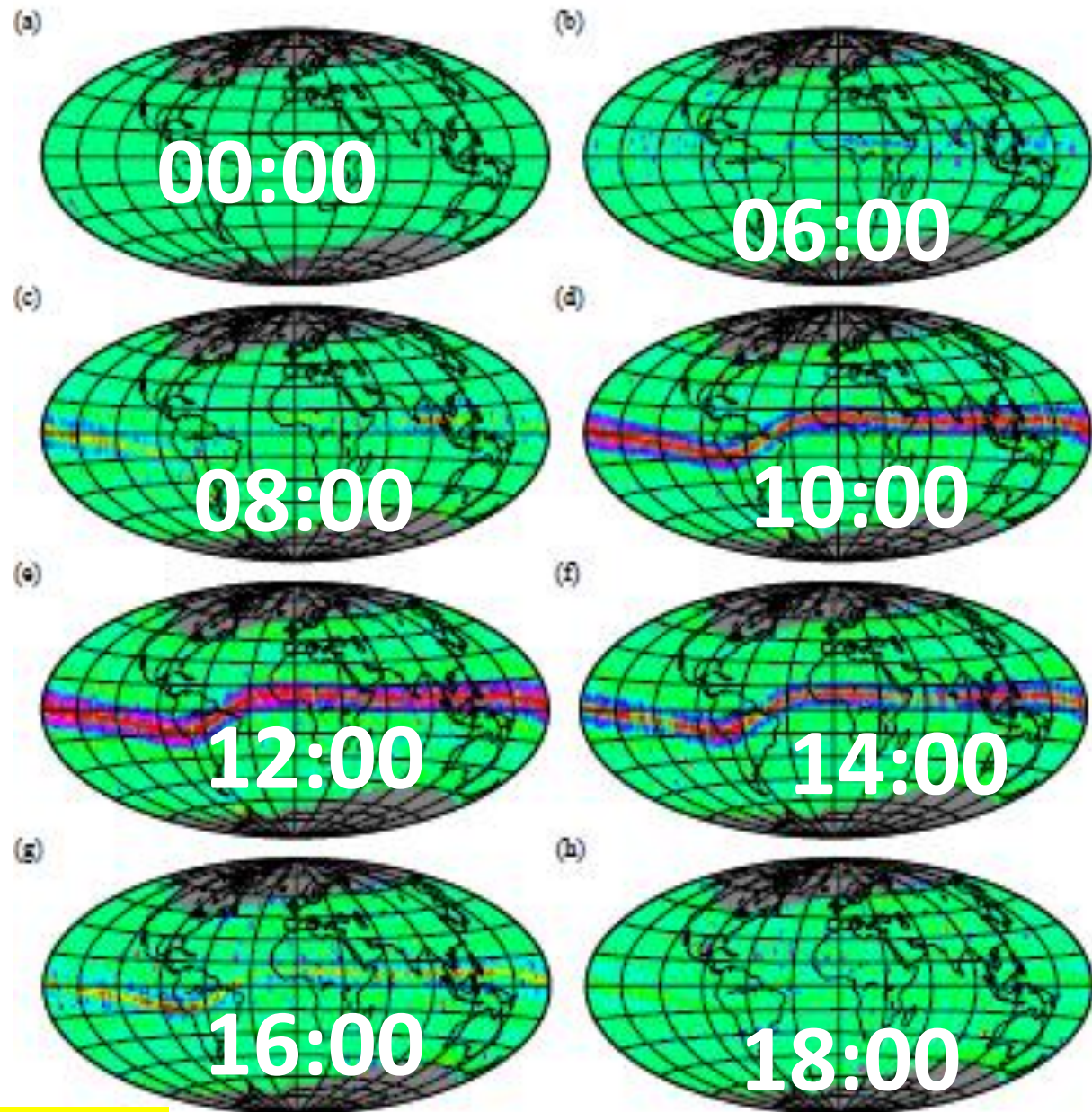

Le Mouél, et al., (2006). The field of the equatorial electrojet from CHAMP data, Ann. Geophys., 24, 515–527



# Estimating EEJ strength

- difference between the horizontal components of magnetic perturbation ( $H$ ) at magnetometers near the equator and outside the edge of the electrojet strip,  $\Delta H$
- provides us an indicator of the strength of the EEJ.

e.g. Onwumechili, 1967; 1997



# Estimating EEJ

- Baseline values
- midnight departures
- Correction for non-cyclic variation
- $S_q$
- EEJ



# daily baseline value

- The concept of local time (LT) is preferred
- Consider time series data in hours as  $H_t$  ( $t= 1, 2, 3, \dots, 24$ )
- The daily baseline value is defined as the average of the 4 hours flanking local midnight (23, 24, 1, 2, hours).

$$H_0 = \frac{H_{23} + H_{24} + H_1 + H_2}{4}$$

*( $H_1, H_2, H_{23}$  &  $H_{24}$  are the hourly values of  $H$  at 01, 02, 23 & 24 hours LT respectively.)*



# Hourly departure

- The hourly departures of  $H$  from *midnight baseline* is *obtained* by subtracting the midnight baseline values for a particular day from the hourly values for that particular day.
- Thus for ' $t$ ' hour LT:

$$\Delta H_t = H_t - H_0 \quad (3)$$

where  $t = 1$  to 24 hrs.

Rabiu et al., 2007



## corrected for non-cyclic variation

- The hourly departure is further corrected for non-cyclic variation, a phenomenon in which the value at 01 LT is different from the value at 24 LT, after Vestine (1967) and Rabiou (2000)
- done by making linear adjustment in the daily hourly values of  $\Delta H$
- *A way of doing this is to consider the hourly departures  $\Delta H$  at 01 LT, 02 LT, 24 LT as  $V_1, V_2, \dots, V_{24}$*
- *Take*

$$\Delta_c = \frac{V_1 - V_{24}}{23}$$

Rabiou et al., 2007

# The Sq

- the linearly adjusted values at these hours are:
- $V_1 + 0\Delta_c; V_2 + 1\Delta_c; V_3 + 2\Delta_c \dots V_{23} + 22\Delta_c; V_{24} + 23\Delta_c$   
(6)

i.e.  $S_t(V) = V_t + (t - 1) \Delta_c$  (7)

- where  $t$  is the local time ranging from 01 to 24.
- The hourly departures corrected for non-cyclic variation gives the solar daily variation in H. Sq(H) denote the solar quiet daily variation in H

Rabiu et al., 2007



UT, the LT is 1.00 p.m. The baseline is defined as the average of the 4 hours flanking local midnight (23, 24, 1, 2, hours). The daily baseline values for the elements used in this research are:

$$H_0 = \frac{H_{23} + H_{24} + H_1 + H_2}{4} \quad (1)$$

$$Z_0 = \frac{Z_{23} + Z_{24} + Z_1 + Z_2}{4} \quad (2)$$

Both  $H_0$  and  $Z_0$  were corrected to the nearest whole number, where  $(H_1, Z_1)$ ,  $(H_2, Z_2)$ ,  $(H_{23}, Z_{23})$  and  $(H_{24}, Z_{24})$  are the hourly values of  $H$  and  $Z$  at 01, 02, 23 and 24 hours LT respectively.

The hourly departures, of  $H$  and  $Z$  from midnight baseline,  $(\Delta H, \Delta Z)$  were obtained by subtracting the midnight baseline values for a particular day from the hourly values for that particular day. Thus for 't' hour LT:

$$\Delta H_t = H_t - H_0 \quad (3)$$

$$\Delta Z_t = Z_t - Z_0 \quad (4)$$

where  $t = 1$  to 24 hrs.

The hourly departure is further corrected for non-cyclic variation, a phenomenon in which the value at 01 LT is different from the value at 24 LT, after Vestine (1967) and Rabiú (2000). This is done by making linear adjustment in the daily hourly values of  $(\Delta H, \Delta Z)$ . A way of doing this is to consider the hourly departures  $(\Delta H, \Delta Z)$  at 01 LT, 02 LT, 24 LT as  $V_1, V_2, \dots, V_{24}$ , and take

$$\Delta_c = \frac{V_1 - V_{24}}{23} \quad (5)$$

the linearly adjusted values at these hours are:

$$V_1 + 0\Delta_c, V_2 + 1\Delta_c, V_3 + 2\Delta_c \dots V_{23} + 22\Delta_c, V_{24} + 23\Delta_c \quad (6)$$

In other words:

$$S_t(V) = V_t + (t - 1)\Delta_c \quad (7)$$

where  $t$  is the local time ranging from 01 to 24.

The hourly departures corrected for non-cyclic variation gives the solar daily variation in  $H$  and  $Z$ .  $Sq(H)$  and  $Sq(Z)$  denote the solar quiet daily variation in  $H$  and  $Z$  respectively; while  $Sd(H)$  and  $Sd(Z)$  denote the solar disturbance daily variation in horizontal intensity and vertical intensity respectively. A set of hourly profiles of  $Sq(H)$ ,  $Sq(Z)$ ,  $Sd(H)$  and  $Sd(Z)$  was obtained for the 60 quiet and 60 disturbed days of the year 1970.

Rabiú et al., 2007

# Estimating EEJ strength

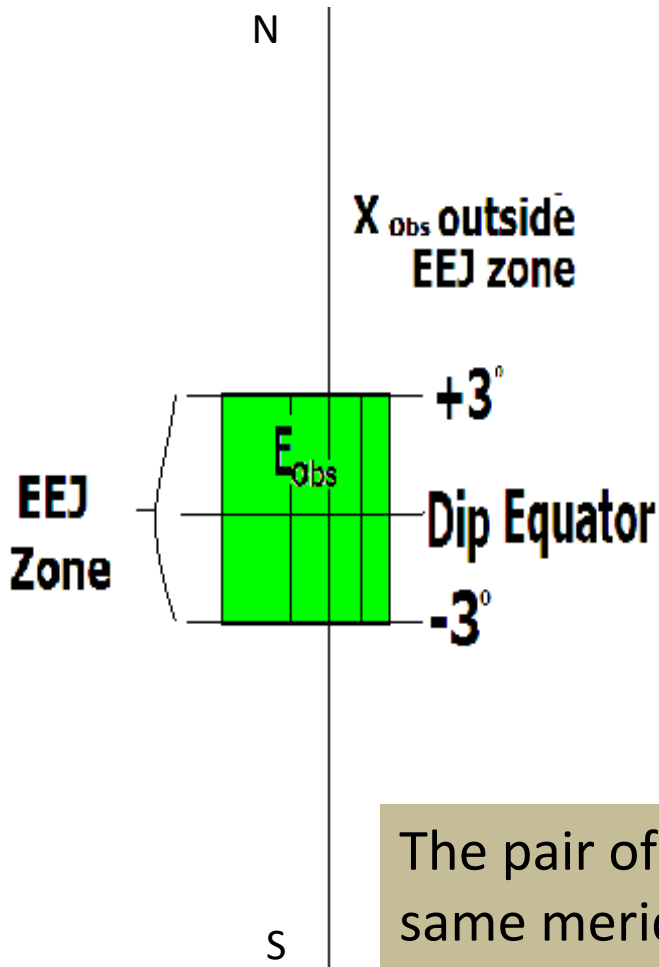

- Consider Observation point E within EEJ strip, &
- Observation point X outside the EEJ strip
- E is under EEJ + Sq
- X is only under Sq
- $EEJ @ E = Sq_E - Sq_X$

The pair of stations must be along, or very close to, the same meridian.

# Alternatively: Estimating EEJ strength

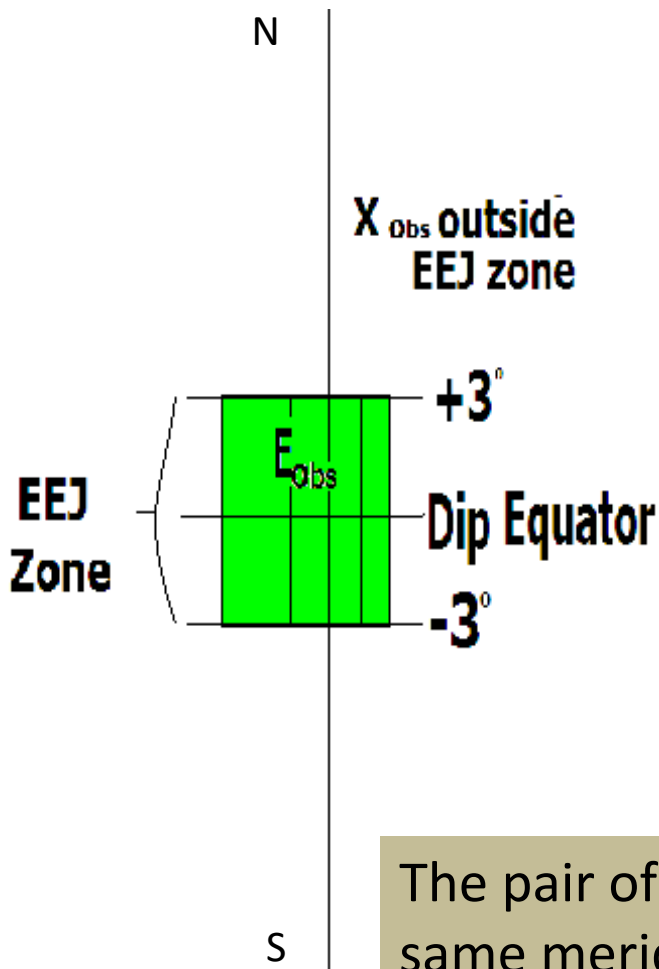

- Consider Observation points: E within EEJ strip, & X outside the EEJ strip
- $H_{diff} = H_E - H_X$
- $H_{diff}$  is then treated for non-cyclic variation to obtain EEJ strength at E;  $H_{EEJ}$

The pair of stations must be along, or very close to, the same meridian.

# Coordinates of the Stations

OBS	GMLat°	GLong ° E	GLat°
ILR	-1.82	4.67	8.50°N
LAG		3.43	3.42°N
AAB	0.18	38.77	9.04°N
NAB		36.80	1.16°S

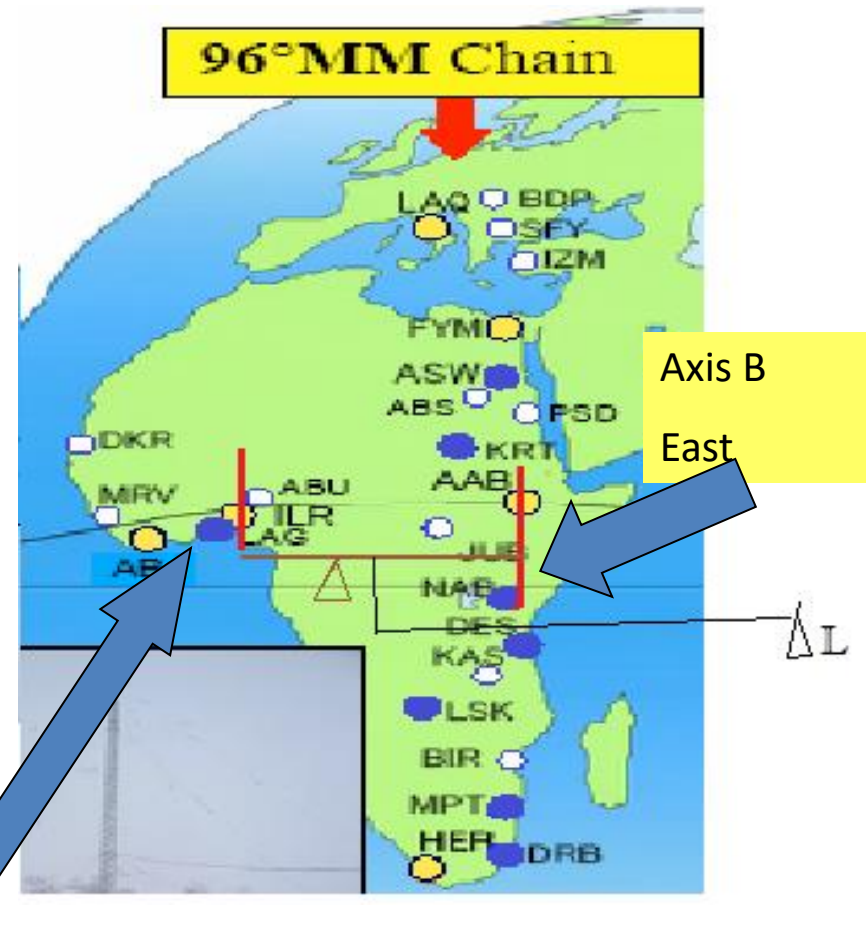

Axis A  
West

Axis B  
East

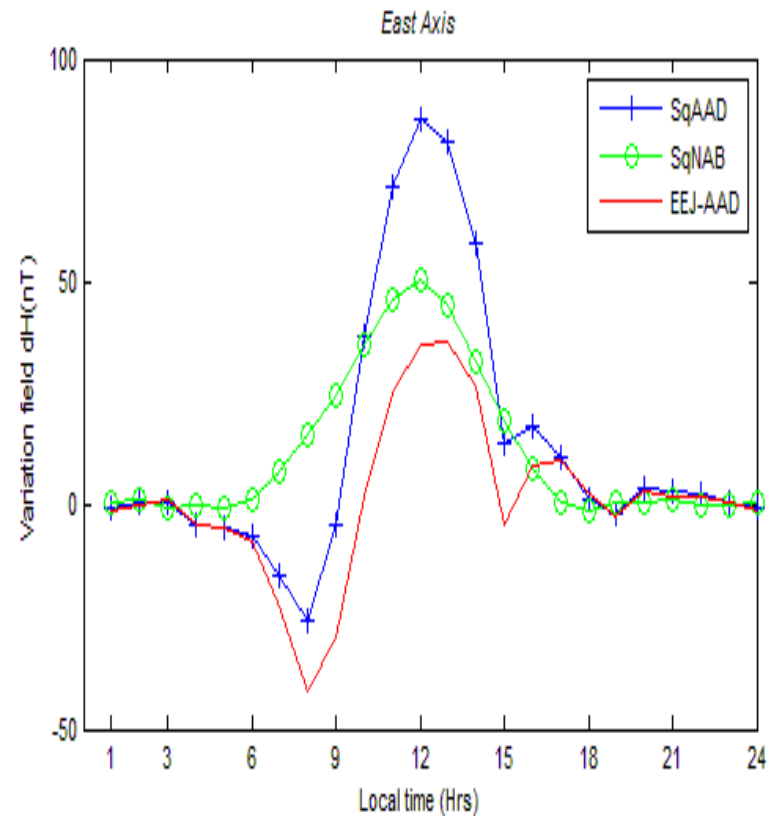
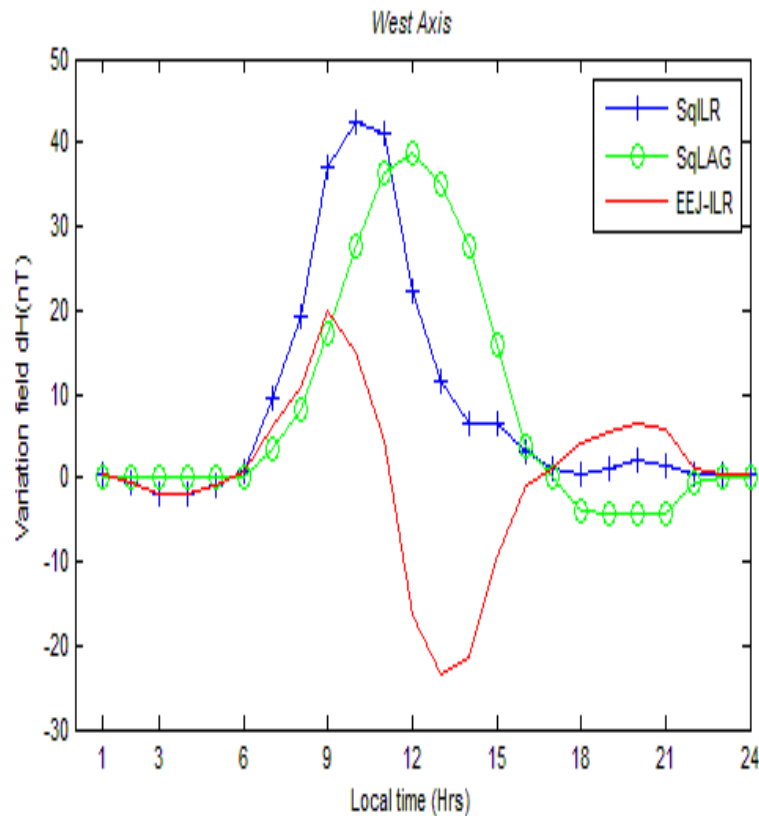

Enhanced Sq at EEJ stations is due to EEJ field



# EEJ along 210° Meridian

Station	Code	<u>Geog.</u>		Dip latitude (°N)
		Lat. °N	long °E	
Muntinlupa	MUT	14.4	121.02	6.79
Yap Island	YAP	9.5	138.08	1.70
Davao	DAV	7.0	125.40	-0.65
Langkawi	LKW	6.3	99.78	-1.88

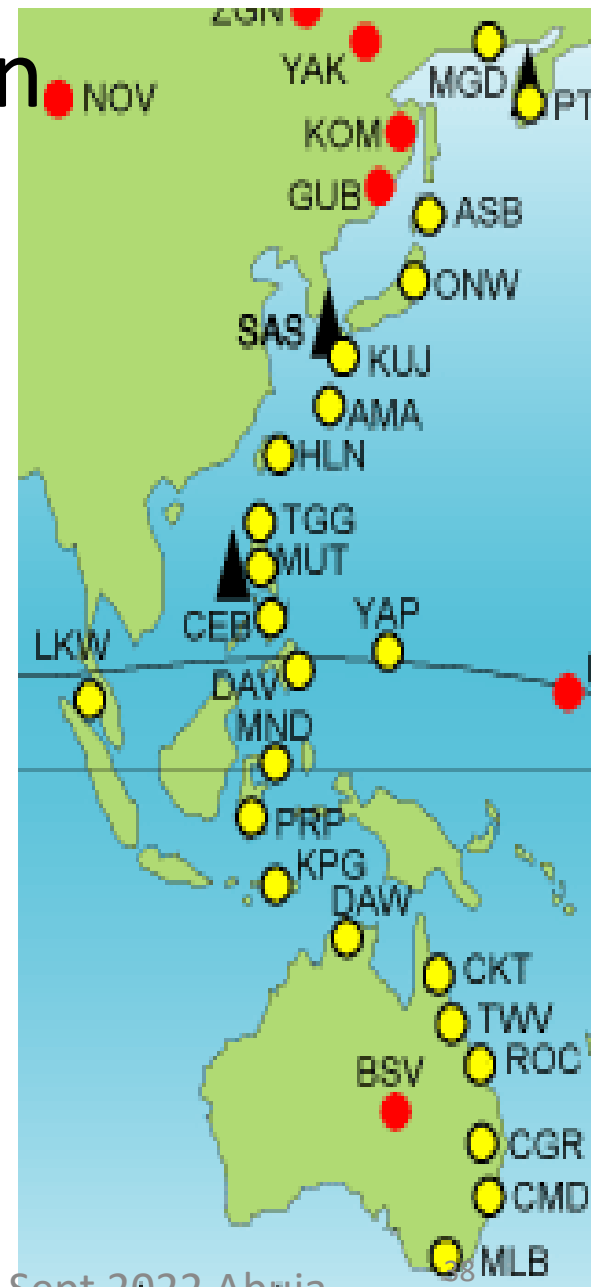

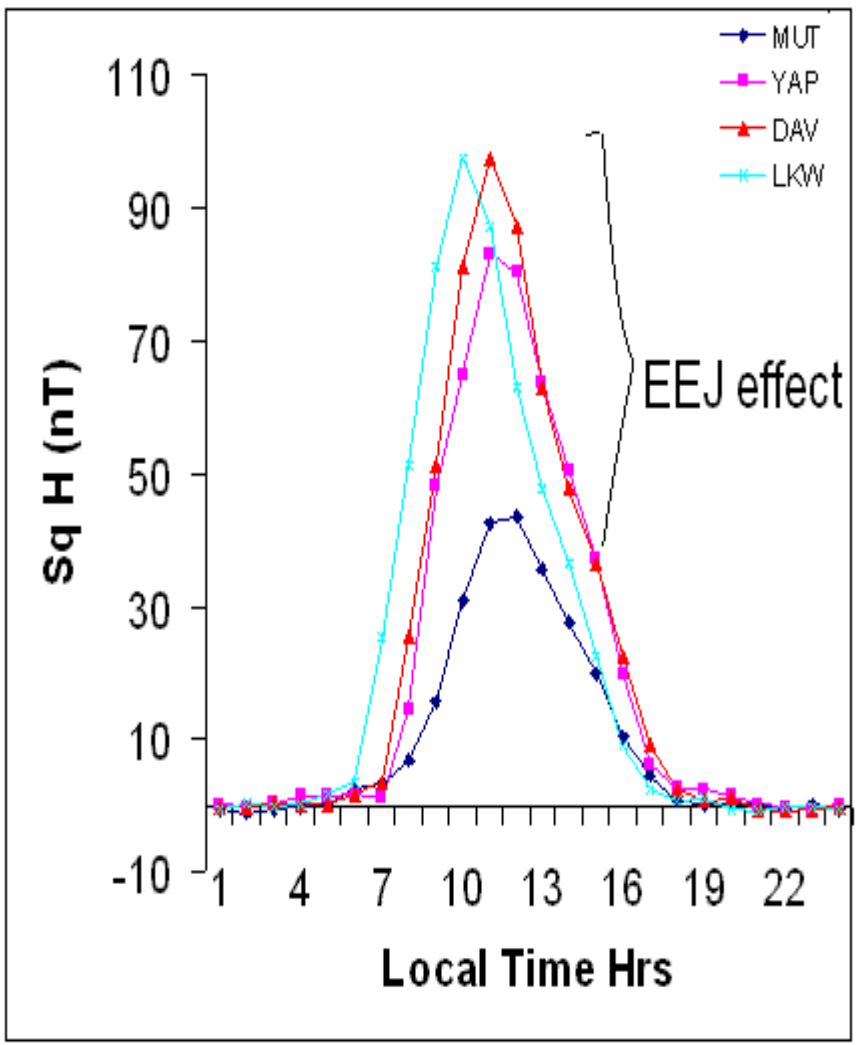

Sq variation in Hon 2nd April 08 (Ap=1)

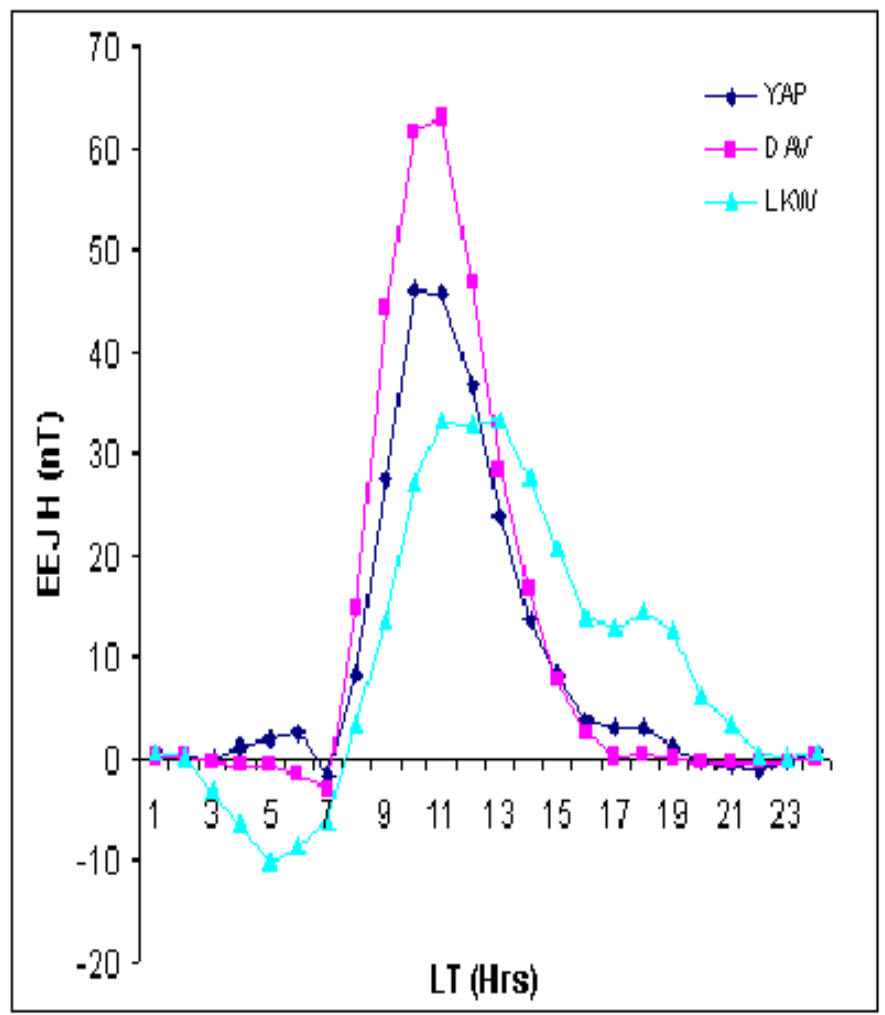

EEJ Strength at the stations



# Typical EEJ Model Evaluation

Onwumechili (1966a, b, c; 1967) presented a two dimensional empirical model of the continuous current distribution responsible for EEJ as:

$$j = \frac{j_0 a^2 (a^2 + \alpha x) b^2 (b^2 + \beta z^2)}{(a^2 + x^2)^2 (b^2 + z^2)^2} \quad (1)$$

Where  $j$  ( $\mu\text{A m}^{-2}$ ) is the eastward current density at the point  $(x, z)$ . The origin is at the centre of the current,  $x$  is northwards, and  $z$  is downwards. The model is extensible to three dimension by introducing the coordinate  $y$  or longitude  $\theta$  or eastwards local time  $t$ .  $j_0$  is the current density at the centre,  $a$  and  $b$  are constant latitudinal and vertical scale lengths respectively,  $\alpha$  and  $\beta$  are dimensionless parameters controlling the current distribution latitudinally and vertically respectively.



**time  $t$  / longitude**

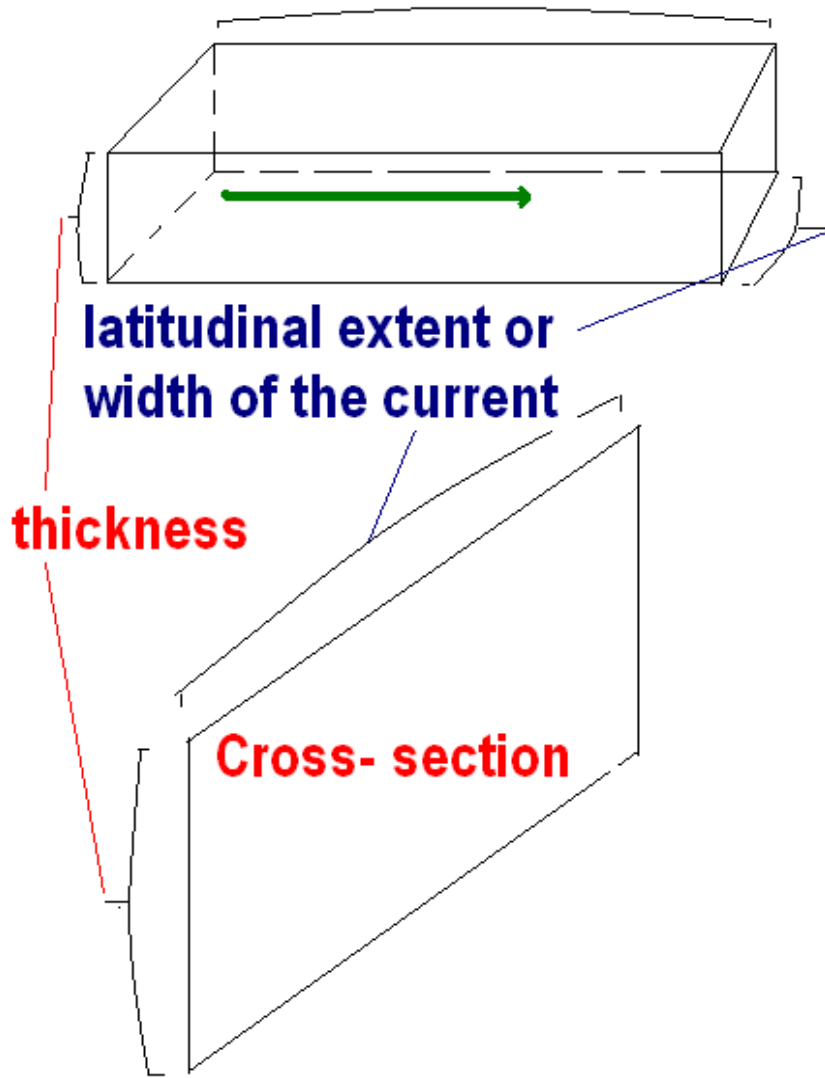

**latitudinal extent or  
width of the current**

**thickness**

**Cross-section**

A Schematic  
diagram of EEJ  
current sheet



# Derivable EEJ parameters

- peak intensity of the forward current at its centre  $J_o$  A/km;
- peak intensity of the return current,  $J_m$  A/km;
- ratio of the peak return to the peak forward current intensity  $J_m/J_o$ ;
- total forward current flowing between the current foci  $I_{fwd}$  kA;
- half of the latitudinal width or the focal distance from the current centre,  $w$  ;
- distance of the peak return current location from the current centre,  $x_m$
- half thickness of the peak current density,  $p$  ;
- latitudinal extent of the current from its centre,  $L1^\circ$ ;
- dip latitude of the electrojet centre  $x_o^\circ$ .

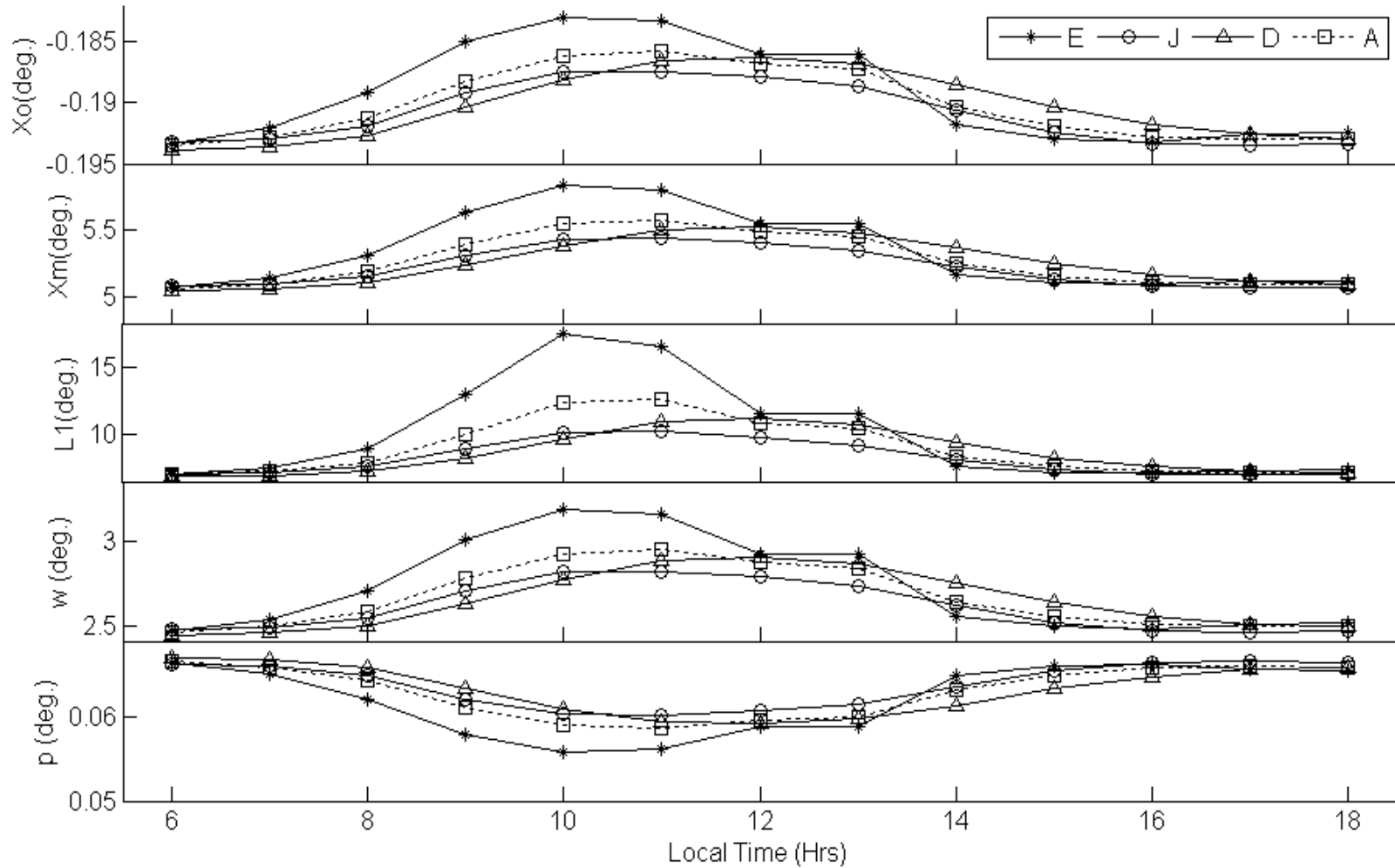

Diurnal variations of the landmark distances of EEJ parameters over India

Rabiu, et al. 2013

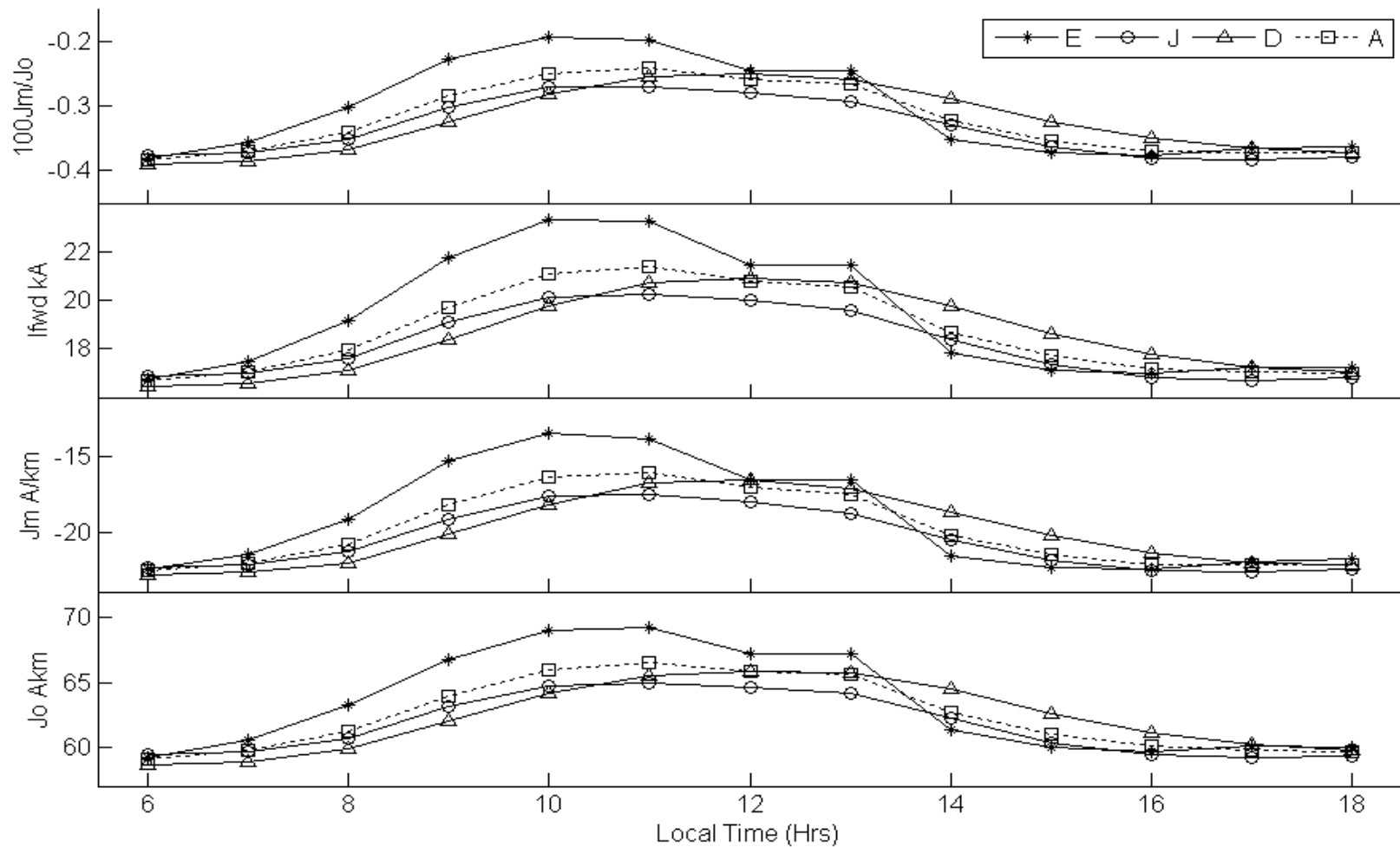

Diurnal variations of the landmark measures of the of EEJ current over India.

Rabiu, et al. 2013

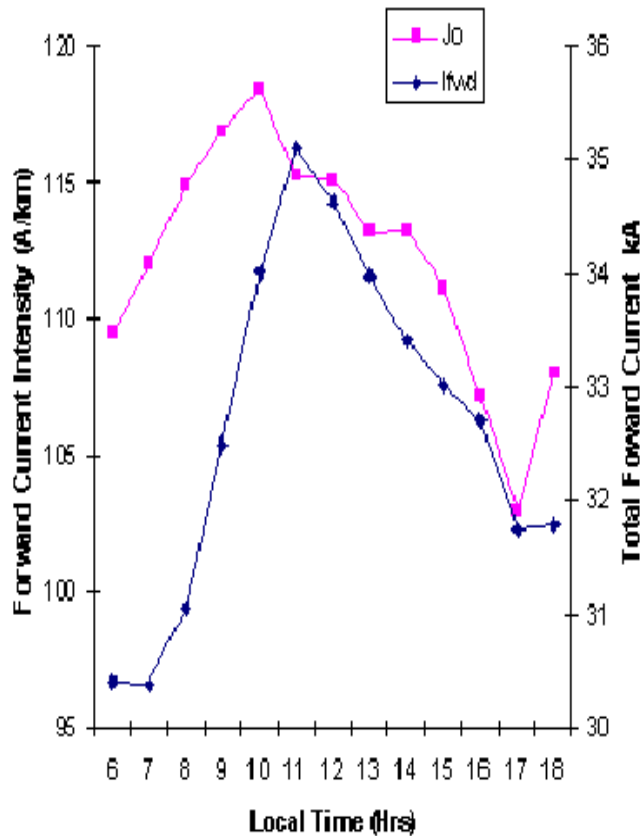

Forward Current Intensity & Total Forward Current

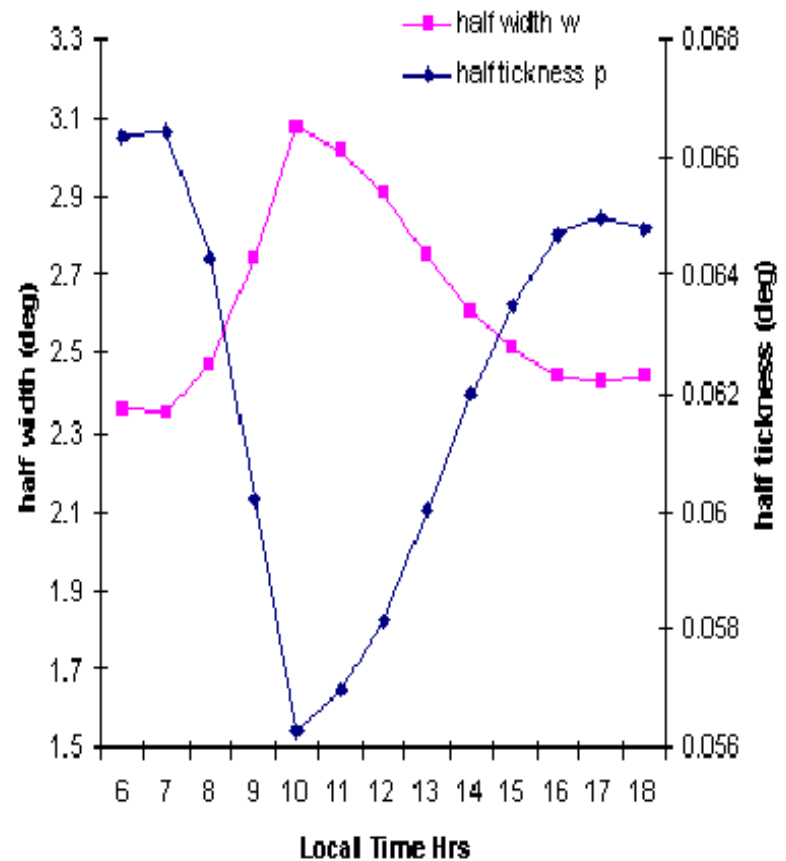

Half width and half thickness of EEJ

EEJ along 210 MM

(Rabiu et al, 2009)

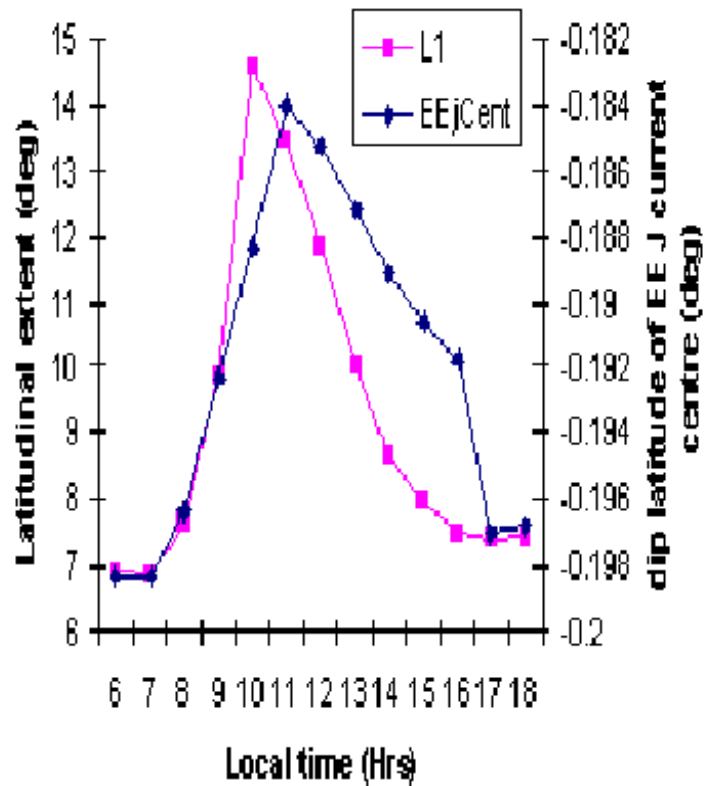

Latitudinal extent and dip latitude of EEJ centre

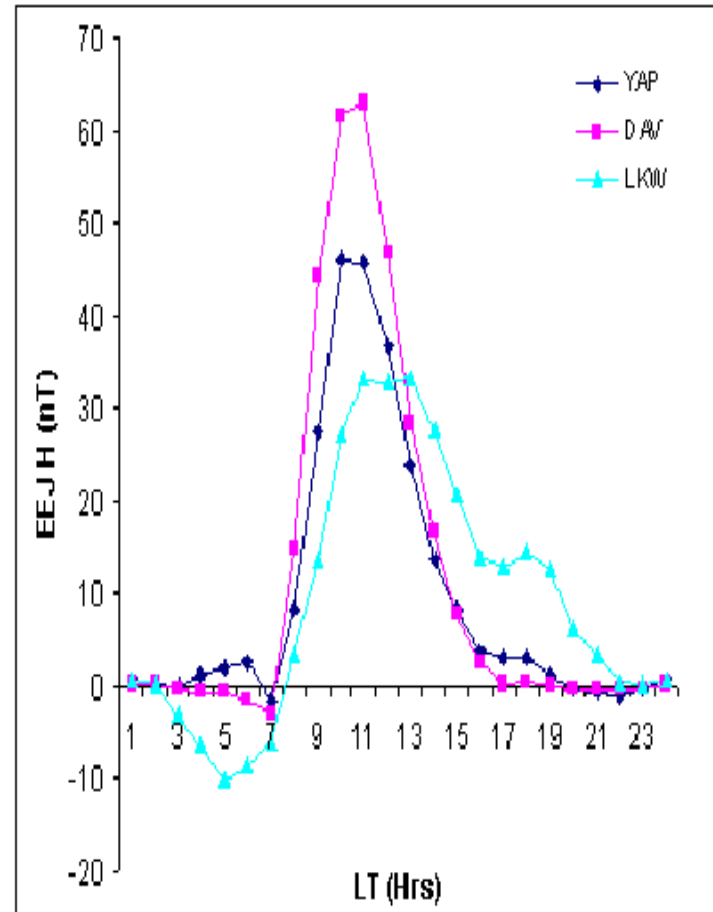

EEJ Strength at the stations

EEJ along 210 MM

(Rabiou et al, 2009)



# LONGITUDINAL VARIABILITY OF EEJ

## Comparison of EEJ at 210 MM with Indian & Brazil sectors

	Jo	Jm	Jm/Jo	lfwd	Dip latitude of EEJ center
210 MM	112.13	-33.80	-0.299	32.67	-0.192
Indian Sector	62.97	-19.48	-0.312	19.01	-0.190
Brazil	148.00	-43.70	-0.290	67.00	-0.189

For 210° MM : Rabiou et al: (2009);  
 Brazil Sector: Rigoti et al, (1999);  
 Indian Sector: Rabiou et al (2013)

# East-West Asymmetry in the African Equatorial Ionosphere

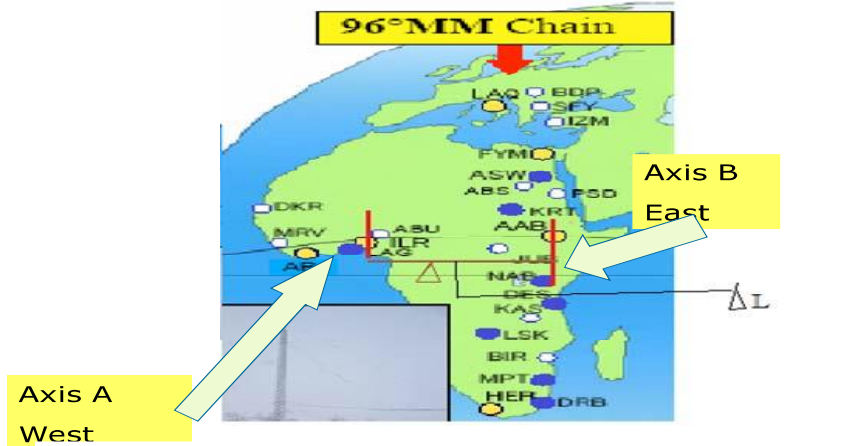

- Rabiou et al., (2011) for the first time clearly revealed that the western African EEJ appears weaker than eastern EEJ
- This discrepancy suggests that there is a process of re-injection of energy in the jet as it flows eastward
- This West-East Asymmetrical behavior in the EEJ strength in the African sector is further confirmed by Rabiou et al (2015) and Yizengaw et al., (2014) using data set from another set of array of magnetometers (AMBER).

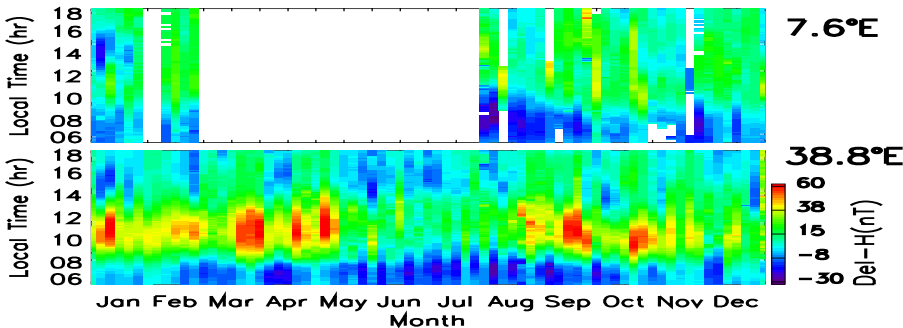
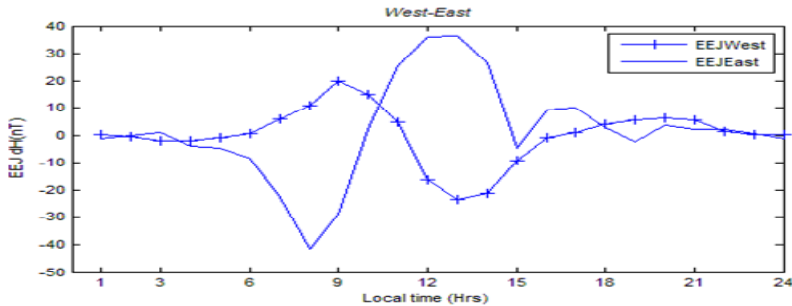



# Longitudinal variation of EEJ

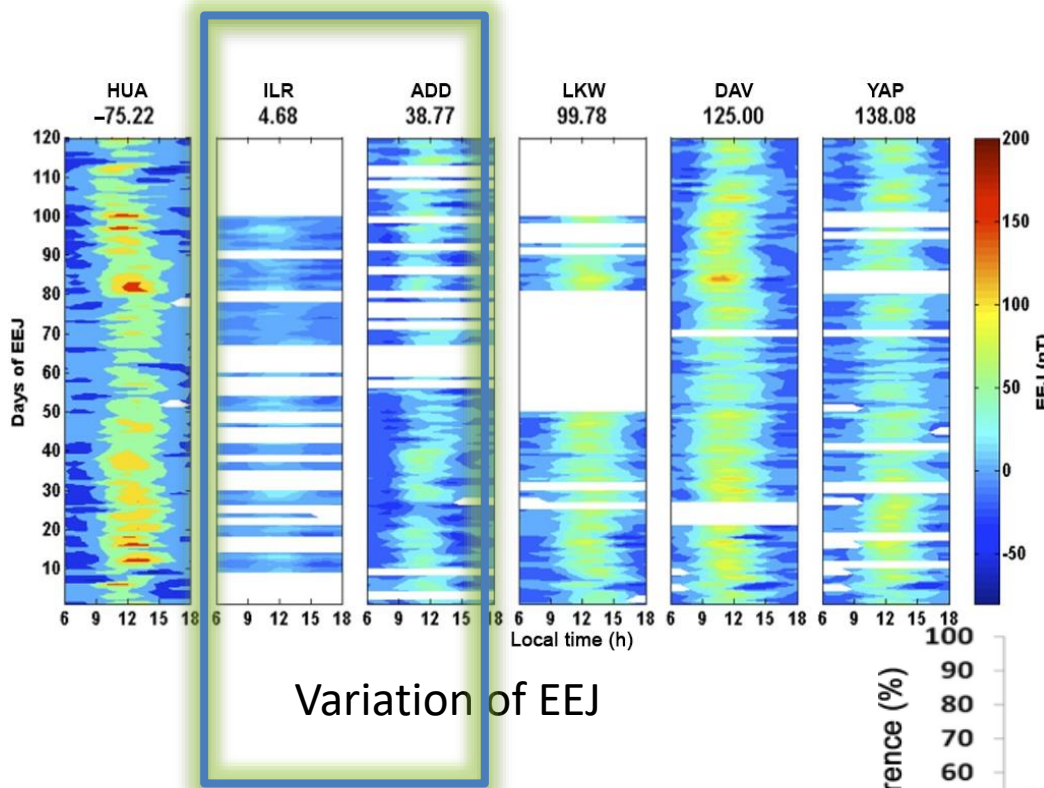

- ✓ the African stations registered the greatest % of occurrence of the CEJ than elsewhere
- ✓ The greatest % occurrence of MCEJ was found at Addis Ababa (eastern Africa)
- ✓ the greatest % occurrence of afternoon CEJ was found at Ilorin (western Africa).

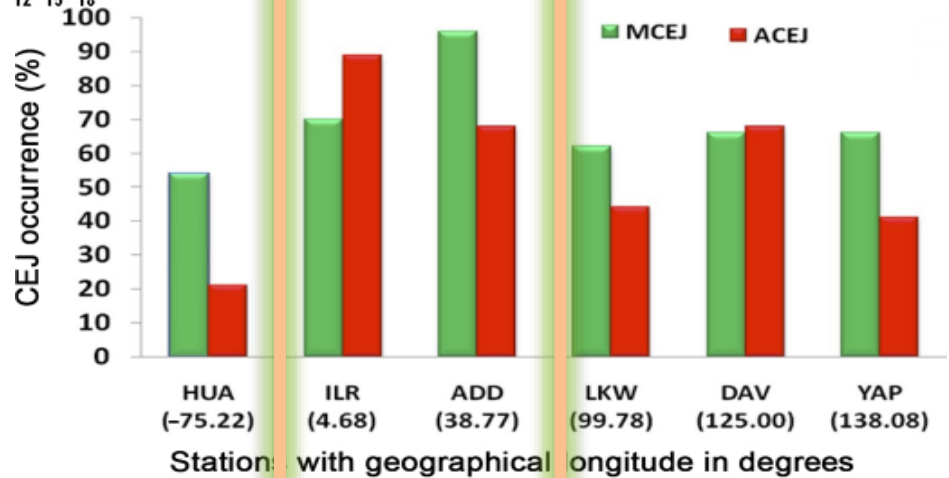

activities that support strong EEJ do inhibit occurrence of the CEJ.

Rabiu et al, 2016, 2017

Yearly % of occurrence of CEJ



# Current Challenges

- New research topics
- e.g. Inter-relationships between EEJ & EIA geometry
- Satellite data under-explored!
- EEJ over Africa is the least studied!
- Ground-based magnetometers

*Collaboration*

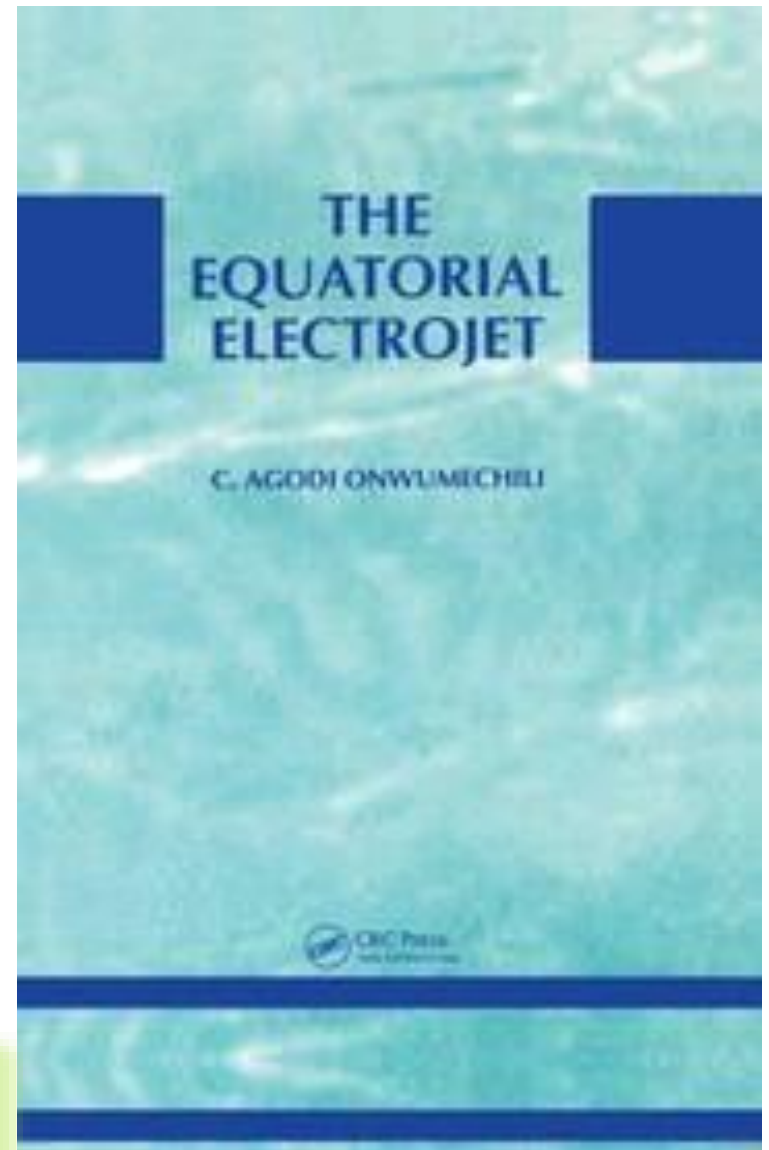



**THANK  
YOU**